

150S-A, 150SR-A

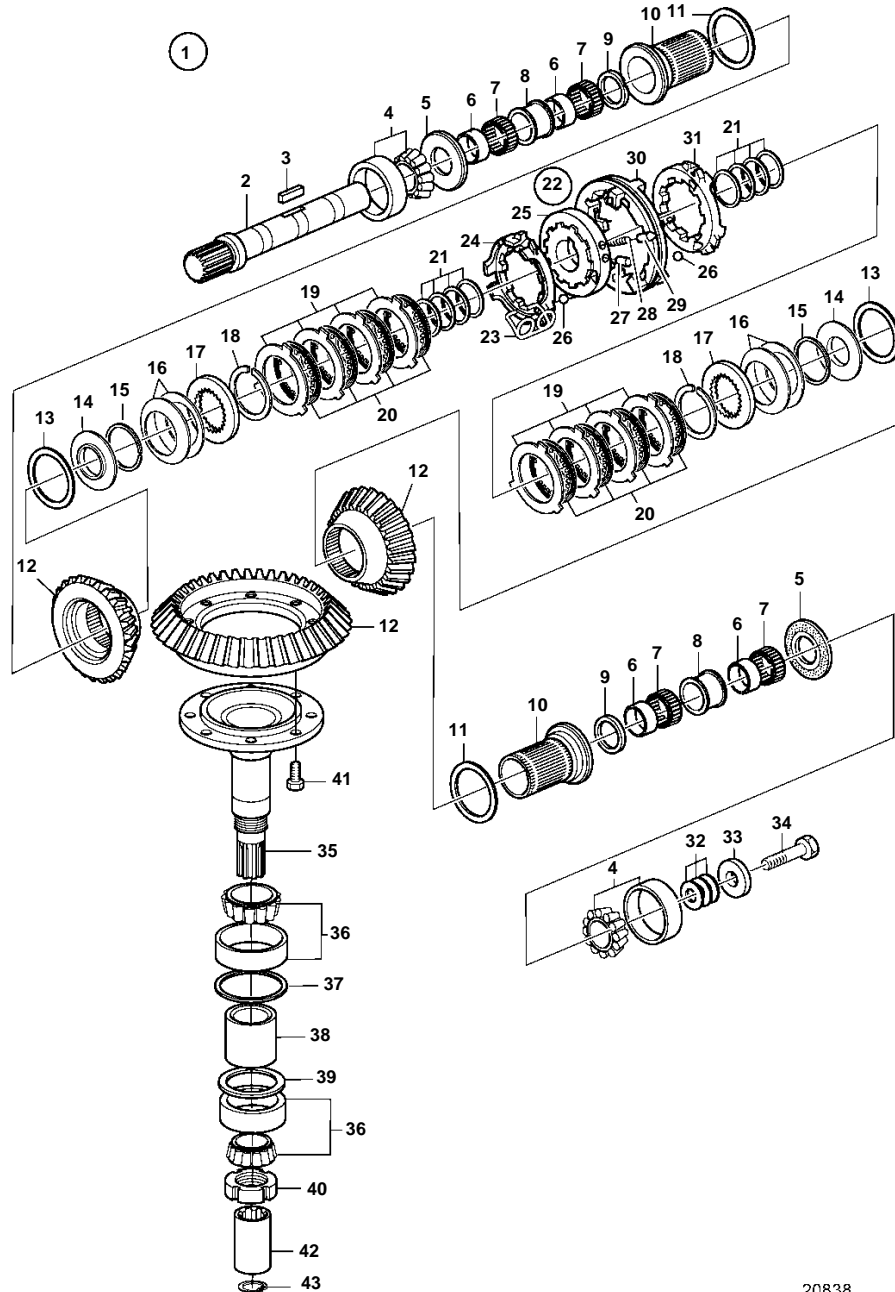

150S-A, 150SR-A

REF	PART NO.	QTY	DESCRIPTION	NOTES
1	888326	1	Gear housing	
2	3808936	1	• Shaft	
3	3582591	2	• Key	
4	183834	2	• Bearing	
5	3582571	2	• Washer	
6	3582904	4	• Bearing race	
7	3582905	4	• Bearing	
8	3582906	2	• Spacer	
9	3586558	2	• Ring	
10	3586546	2	• Bushing	
11	3582908	X	• Shim	TH = 0,10mm
	3586721	X	• Shim	TH = 0.15mm
	3582911	X	• Shim	TH=0,20mm
	3582910	X	• Shim	TH = 0,30mm
	3586723	X	• Shim	TH = 0,50mm
12	3586547	1	• Gear set	
13	3582566	X	• Shim	TH = 0,10mm
	3582567	X	• Shim	TH = 0.15mm
	3582568	X	• Shim	TH=0,20mm
	3582569	X	• Shim	TH = 0,30mm
	3586724	X	• Shim	TH = 0,50mm
	3586728	X	• Shim	TH = 1,00mm
14	3586555	2	• Spacer	
15	3582917	2	• Lock ring	
16	3586557	2	• Spring washer	
17	3586556	2	• Disc	
18	3582577	2	• Lock ring	
19	3582579	8	• Disc	
20	3582578	8	• Disc	
21	3582872	X	• Shim	TH = 0.15mm
	3583430	X	• Shim	TH=0,20mm
	3583429	X	• Shim	TH = 0,30mm
	3582580	X	• Shim	TH=0,40mm
	3582581	X	• Shim	TH = 0,50mm
	3582582	X	• Shim	TH = 0,60mm
	3582583	X	• Shim	TH = 0,70mm
22	3586517	1	• Shift mechanism	
23	3582024	3	• • Spring	
24	3586532	1	• • Plate	
25	3582898	1	• • Hub	
26	3582585	6	• • Ball	
27	3582590	3	• • Pin	
28	3582588	3	• • Spring	
29	3582589	3	• • Pin	
30	3586525	1	• • Guide sleeve	
31	3586533	1	• • Plate	

150S-A, 150SR-A

REF	PART NO.	QTY	DESCRIPTION	NOTES
32	3586725	X	· Shim	TH = 0,10mm
	3586726	X	· Shim	TH = 0.15mm
	3582900	X	· Shim	TH=0,20mm
	3582901	X	· Shim	TH = 0,50mm
	3586727	X	· Shim	TH = 1,00mm
33	3582899	1	· Washer	
34	3808717	1	· Screw	
35	3588826	1	· Shaft	
36	11041	2	· Roller bearing	
37	3586729	X	· Shim	TH = 0,10mm
	3582874	X	· Shim	TH = 0.15mm
	3582875	X	· Shim	TH=0,20mm
	3586730	X	· Shim	TH = 0,50mm
	3586731	X	· Shim	TH = 1,00mm
38	3586509	1	· Spacer	
39	3586657	X	· Shim	TH = 0,10mm
	3586658	X	· Shim	TH = 0.15mm
	3586659	X	· Shim	TH=0,20mm
	3586660	X	· Shim	TH = 0,30mm
	3582580	X	· Shim	TH=0,40mm
40	3586732	1	· Lock nut	
41	955271	8	· Screw	
42	3586676	1	Sleeve	
43	3586678	1	Lock ring	