

150S-A, 150SR-A

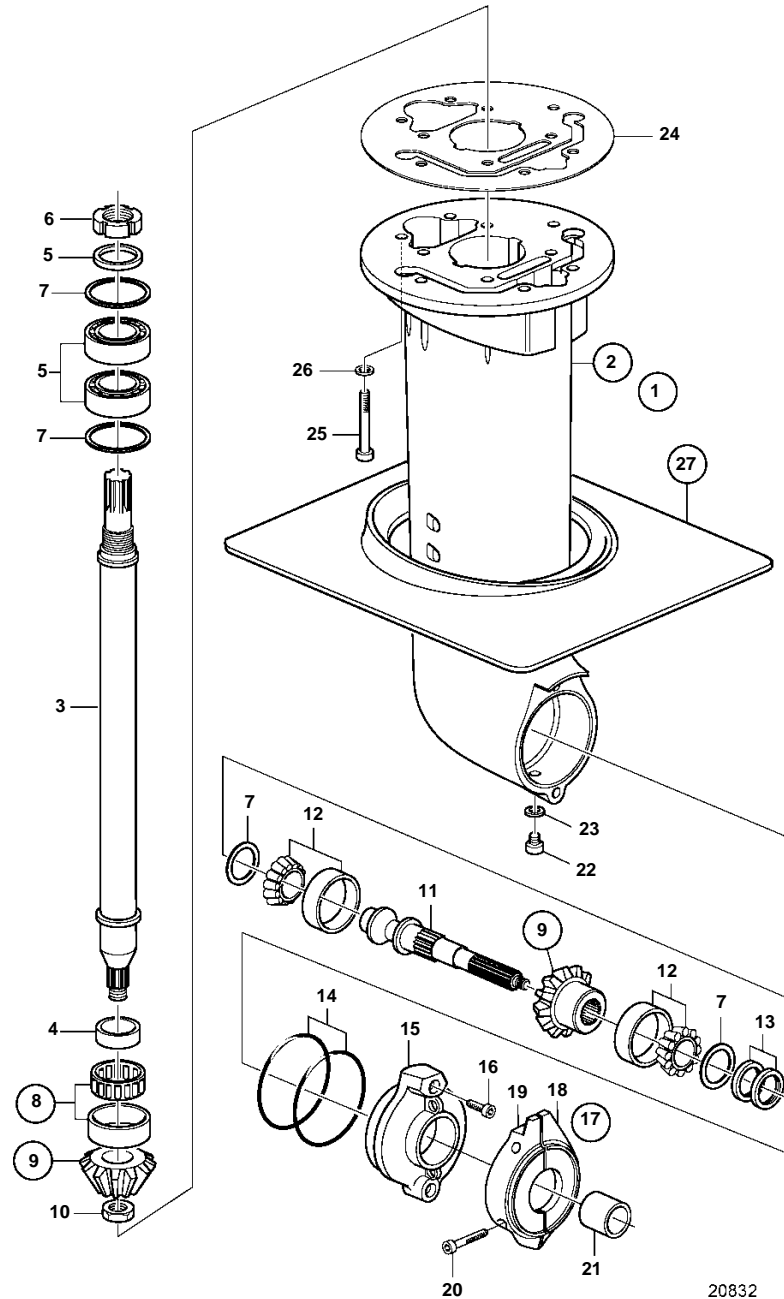

150S-A, 150SR-A

REF	PART NO.	QTY	DESCRIPTION	NOTES
1	889670	1	Gear housing	
2	3584493	1	· Gear housing	
3	889740	1	· · Shaft	
4	889736	1	· Inner ring	
5	11041	2	· Roller bearing	
6	3586672	1	· Lock nut	
7	3586729	X	· Shim	TH = 0,10mm
	3582874	X	· Shim	TH = 0,15mm
	3582875	X	· Shim	TH=0,20mm
	3586730	X	· Shim	TH = 0,50mm
	3586731	X	· Shim	TH = 1,00mm
8	3586323	1	· Needle bearing	
9	3584421	1	· Gear set	
10	3808938	1	· Nut	
11	889742	1	· Driveshaft	
12	183647	2	· Roller bearing	
13	873108	2	· Sealing ring	
14	889672	2	· O-ring	
15	3584065	1	· Bearing housing	
16	946541	2	· Screw	L=25mm
17	3586963	1	· Anode kit	
18		1	· · Anode	
19		1	· · Anode	LEFT
20	963688	2	· · Allen head screw	L=40mm
21	3582887	1	· Spacer	
22	3854539	1	· Plug	
23	3855081	1	· · O-ring	
24	3586693	1	Gasket	
25	963700	2	Allen head screw	
26	941670	2	Washer	
27	3583365	1	Mounting kit	