

TWD1630G, TAD1630G, TAD1630GE, TAD1631G, TAD1631GE

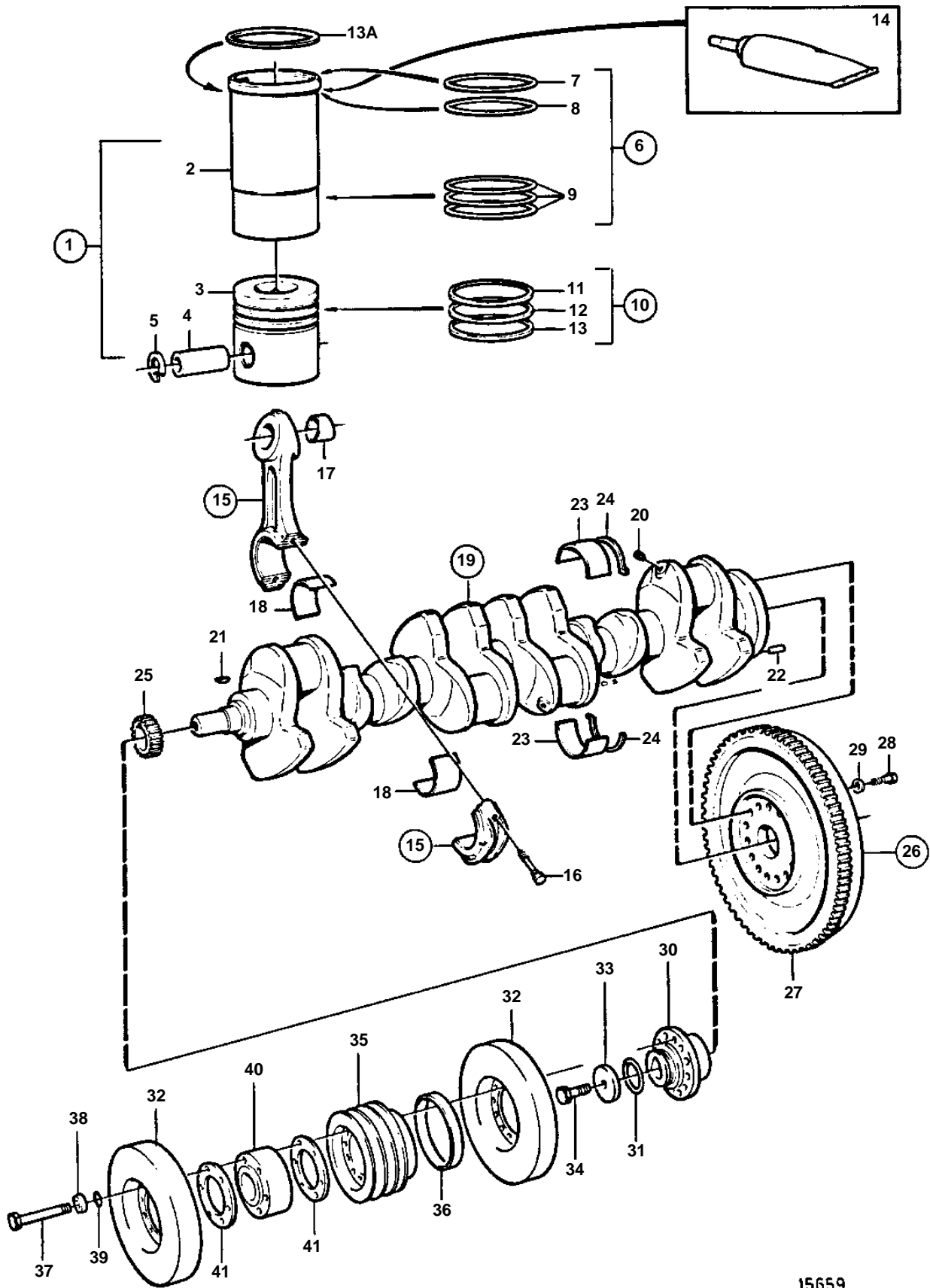

15659

TWD1630G, TAD1630G, TAD1630GE, TAD1631G, TAD1631GE

REF	PART NO.	QTY	DESCRIPTION	SEE SEC.	NOTES
1		6	Cylinder liner kit		SN-2160022233. Replaced by conversion kit 3826321.. Rebuilt engines are marked with two punch marks after the serial number.
	3826321	1	Conversion kit		Rebuilt engines are marked with two punch marks after the serial number.. The kit contains 6 ea cylinderliner kits 3826320 and 6 ea connecting rods 1556319.
			Bulletin 47-05	47-05-EN	New Piston & Piston Rings
2		6	· Cylinder liner		
3		6	· Piston		
4	1556940	6	· Piston pin		(1556200) L=120mm. Rebuilt engines are marked with two punch marks after the serial number.
5	914532	12	· Snap ring		
6	270935	6	· Sealing ring kit		
7	1543507	6	· · Sealing ring		
8		6	· · Sealing ring		
9		18	· · Sealing ring		
10	3826935	6	· Piston ring kit		SN-2160022233. Rebuilt engines are marked with two punch marks after the serial number.
11		6	· · Compression ring		
12		6	· · Compression ring		
13		6	· · Oil scraper ring		
13A	1548125	X	Shim		TH=0,20mm
	1548126	X	Shim		TH = 0,30mm
	1548127	X	Shim		TH = 0,50mm
14	1161277	X	Sealant		20g
15		6	Connecting rod		SN-2160022233. Rebuilt engines are marked with two punch marks after the serial number.
17	1543034	6	· Bushing		SN-2160022233. Rebuilt engines are marked with two punch marks after the serial number.. Rebuilt Engines must have Bushing 1556321.
18	270796	6	Big end bearing kit		STD D
	270797	6	Big end bearing kit		U.S=0,25mm
	270798	6	Big end bearing kit		U.S=0,50mm
	270799	6	Big end bearing kit		U.S=0,75mm
19	863792	1	Crankshaft		
20	978130	6	· Plug		
21	422253	1	· Woodruff key		
22	950645	1	· Pin		
23	270792	7	Main bearing kit		STD D
	270793	7	Main bearing kit		U.S=0,25mm
	270794	7	Main bearing kit		U.S=0,50mm
	270795	7	Main bearing kit		U.S=0,75mm
24	270929	1	Thrust washer kit		STD D
	270930	1	Thrust washer kit		O.S=0,10mm
	270931	1	Thrust washer kit		O.S=0,20mm
	270932	1	Thrust washer kit		O.S=0,30mm
25	1543444	1	Gear		
26	3825678	1	Flywheel		SN-2160048210
	889617	1	Flywheel		SN2160048211-
27	8193939	1	· Gear ring		
28	849912	14	Screw		
	1677893	14	Screw		
29	1543563	14	Washer		
30	848851	1	Hub		
31	945512	1	O-ring		
32	1543834	2	Vibration damper		

TWD1630G, TAD1630G, TAD1630GE, TAD1631G, TAD1631GE

REF	PART NO.	QTY	DESCRIPTION	SEE SEC.	NOTES
33	422124	1	Washer		
34	862504	1	Screw		
35	3825893	1	V-belt pulley		3 GROOVE. Earlier production of 6 ea of screw is replaced by 12 ea screw.
36	3829683	1	• Wear ring		
37	973253	12	Screw		Earlier production of 6 ea of screw is replaced by 12 ea screw.
38	4956010	12	Washer		Earlier production of 6 ea of screw is replaced by 12 ea screw.
39	955974	12	O-ring		Earlier production of 6 ea of screw is replaced by 12 ea screw.
40		1	Hub		Replaced by 1 ea 3825885 hub, 1 ea 3825893 pulley, 2 ea 3825886 gasket, 6 ea 973253 screw, 6 ea 4956010 washer and 12 ea 955974 o-ring.. Earlier production of 6 ea of screw is replaced by 12 ea screw.
	3825885	1	Hub		
41	3825886	2	Gasket		Earlier production of 6 ea of screw is replaced by 12 ea screw.