

TD71A,TD71AW,TD71ACE,TD71AG,TD71AGP,TD71AP,TD71APB

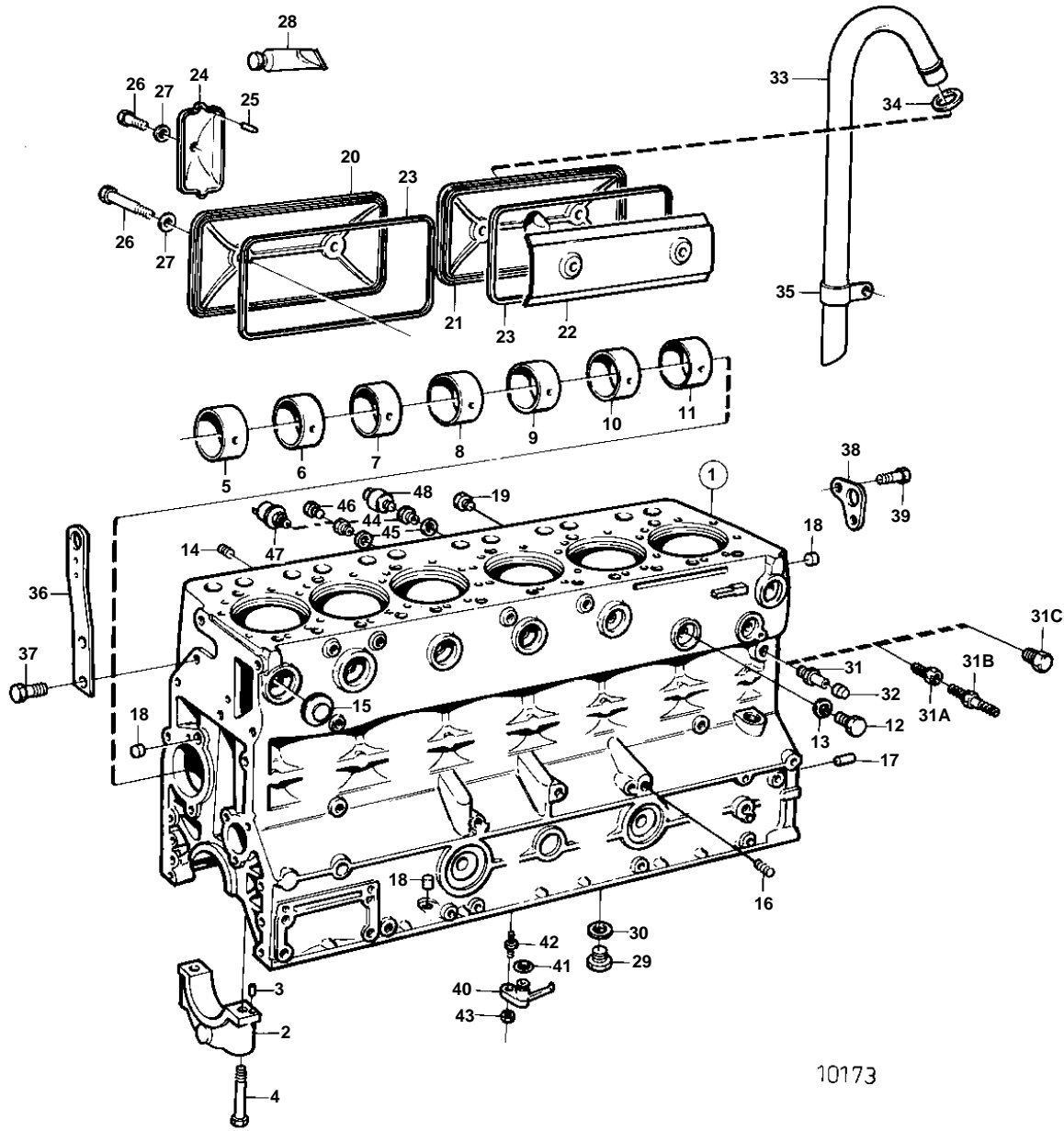

10173

TD71A,TD71AW,TD71ACE,TD71AG,TD71AGP,TD71AP,TD71APB

REF	PART NO.	QTY	DESCRIPTION	NOTES
1	471400	1	Cylinder block	REPLACED BY 1EA CYLINDER BLOCK 477990, 1EA OIL PRESSURE PIPE (CYLINDER BLOCK-FUEL INJECTION PUMP), 477986, 1EA HOLLOW SCREW 969299 AND 2EA GASKET 11994.
	477990	1	Cylinder block	
2		7	• BEARING CAP	*
3	422426	1	• Pin	
4	465899	14	• Screw	
5	422076	1	• Bushing	*
6	422077	1	• Bushing	
7	422078	1	• Bushing	
8	422079	1	• Bushing	
9	422080	1	• Bushing	
10	422081	1	• Bushing	
11	422082	1	• Bushing	
12	467367	1	• Plug	
13	469328	1	• Gasket	
14	422369	7	• Plug	
15	1542263	6	• Expansion plug	
16	968145	1	• Plug	
17	191171	2	• Pin	
18	955082	4	• Cap plug	
	955082	1	Cap plug	
19	946559	1	Plug	
20	420120	1	Inspection cover	
21	420121	1	Inspection cover	
22	471858	1	Splash plate	
23	421121	2	Gasket	
24	471854	1	Cover	
25	951974	1	Spring pin	
26	471855	5	Screw	
27	471856	5	Sealing ring	
28	1161231	1	Sealant	
29	966146	1	Plug	
30	947629	1	Gasket	
31	946121	1	Nipple	EARLY TYPE. *REPLACED BY 1PC 479954 AND 1PC 947893.
31A	479954	1	Nipple	
31B	947893	1	Drain cock	
31C	479956	1	Plug	TD71ACE
32	476279	1	Protective cap	TID.UTF.
33	471857	1	Tube	
34	421158	1	Sealing ring	
35	968124	1	Clamp	
36	848346	1	Lift iron	STD
	420556	1	Lifting eye	WHEN LOW TURBO IS INSTALLED.
37	965191	2	Screw	L = 30 MM
38	477261	2	Lift iron	(471510)
	849985	2	Lifting eye	WHEN LOW TURBO IS INSTALLED.
39		4	SCREW	
40	420628	6	Nozzle	(466836)
41	466874	6	Sealing ring	
42	471596	6	Stud	
43	948570	6	Lock nut	
44	421528	2	Reduction nipple	
45	947622	2	Gasket	
46	191026	2	Plug	ALT.. PLUG FOR OIL PRESSURE POINT.
47		1	OIL PRESSURE SENSOR	SEE GROUP 3
48		1	OIL-PRESSURE CONTACT	SEE GROUP 3