

TD610G, TWD610G, TD710G, TWD710G, TAD730G, TWD740GE, TAD740GE, TAD741GE

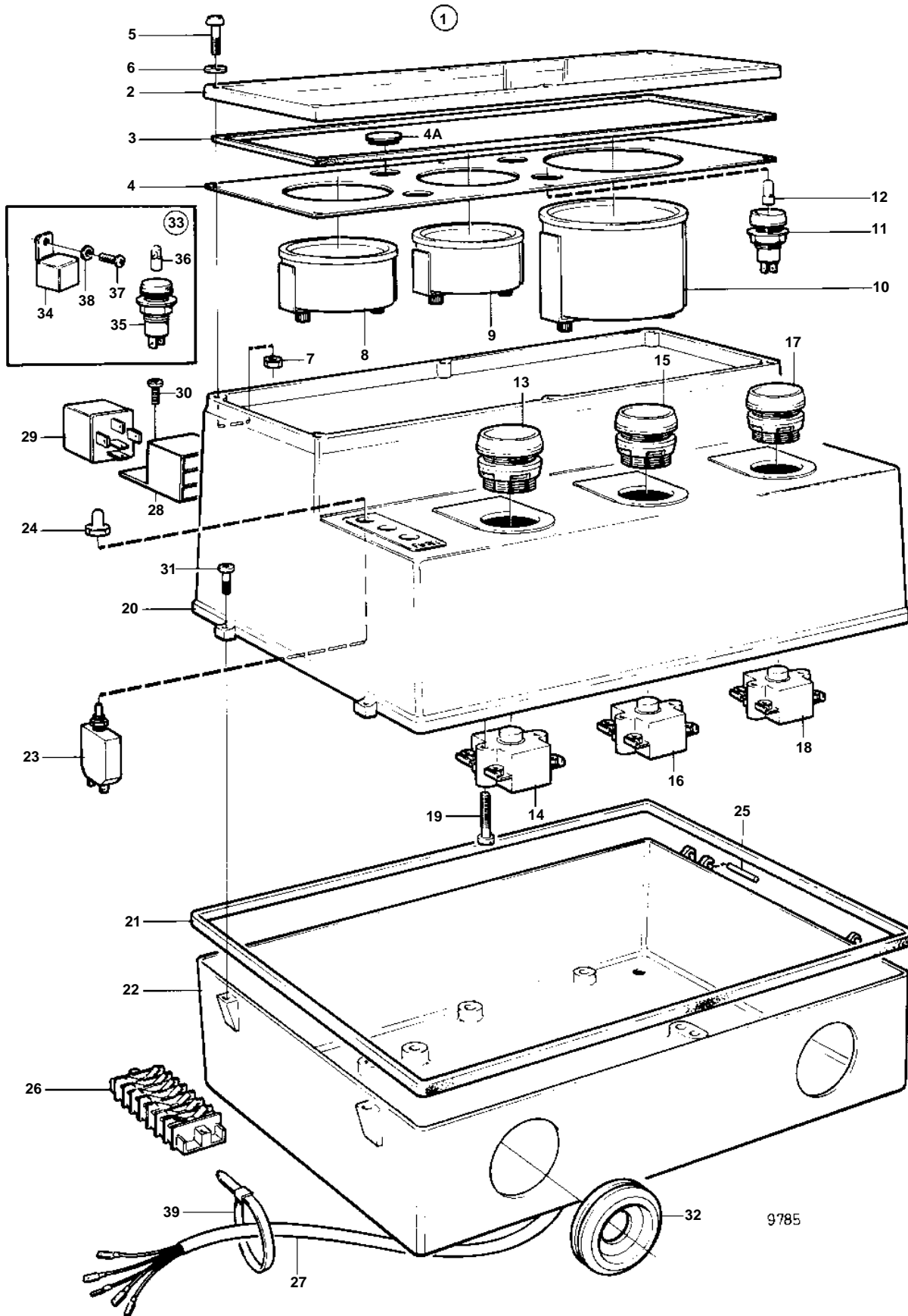

TD610G, TWD610G, TD710G, TWD710G, TAD730G, TWD740GE, TAD740GE, TAD741GE

REF	PART NO.	QTY	DESCRIPTION	NOTES
1		1	Instrument panel	
2	873654	1	• Cover glass	(849842)
3	849885	1	• Sealing strip	
4	863800	1	• Instrument panel	
4A		3	• Protecting plug	
5	849963	6	• Screw	
6	862501	6	• Gasket	
7	965483	6	• Nut	
8	849849	1	• Oil pressure gauge, oil-pressure	24V
9	849848	1	• Thermometer, temperature	24V
10	854908	1	• Tachometer, hour/tachometer	Replaced by operating clock/tachometer 873998 and intermediate ring 873721., 24V
11	849966	1	• Bulb socket	Warning lamp, charging.
12	182034	1	• Bulb	
13	863102	1	• Push button	RED
14	873791	1	• Switch	GREEN-RED (863115)
15	3817578	1	• Switch	BLACK (863104)
16	873791	1	• Switch	GREEN-RED (863115)
17	863103	1	• Push button	GREEN
18	873792	1	• Switch	GREEN (863116)
19	956063	6	• Screw	
20	849838	1	• Cover	
21	849840	1	• Sealing strip	
22	849839	1	• Box	
23	968821	1	• Fuse	16A
	966689	2	• Fuse	8A
24	862006	3	• Protective cap	
25	951967	2	• Spring pin	
26	849992	1	• Terminal block	5-POLE
	849993	2	• Terminal block	7-POLE
27	862137	1	• Cable trunk	
28	977184	3	• • Tab housing	(946556)
29	1504951	2	• Relay	24V
30	956074	3	• Screw	
31	862281	2	• Screw	
32	943920	1	• Protecting plug	
33			Alarm separator	
34	863724	1	• Alarm separator	
35	863721	1	• Bulb socket	Warning lamp, low coolant level.
	863722	1	• Bulb socket	Warning lamp, low oil pressure.
	863723	1	• Bulb socket	Warning lamp, high coolant temperature.
36	182034	3	• Bulb	
37		1	• Cross recessed screw	
38	955892	1	• Washer	
39	948211	X	Strip clamp	