

TAD1230G, TAD1231GE, TAD1232GE

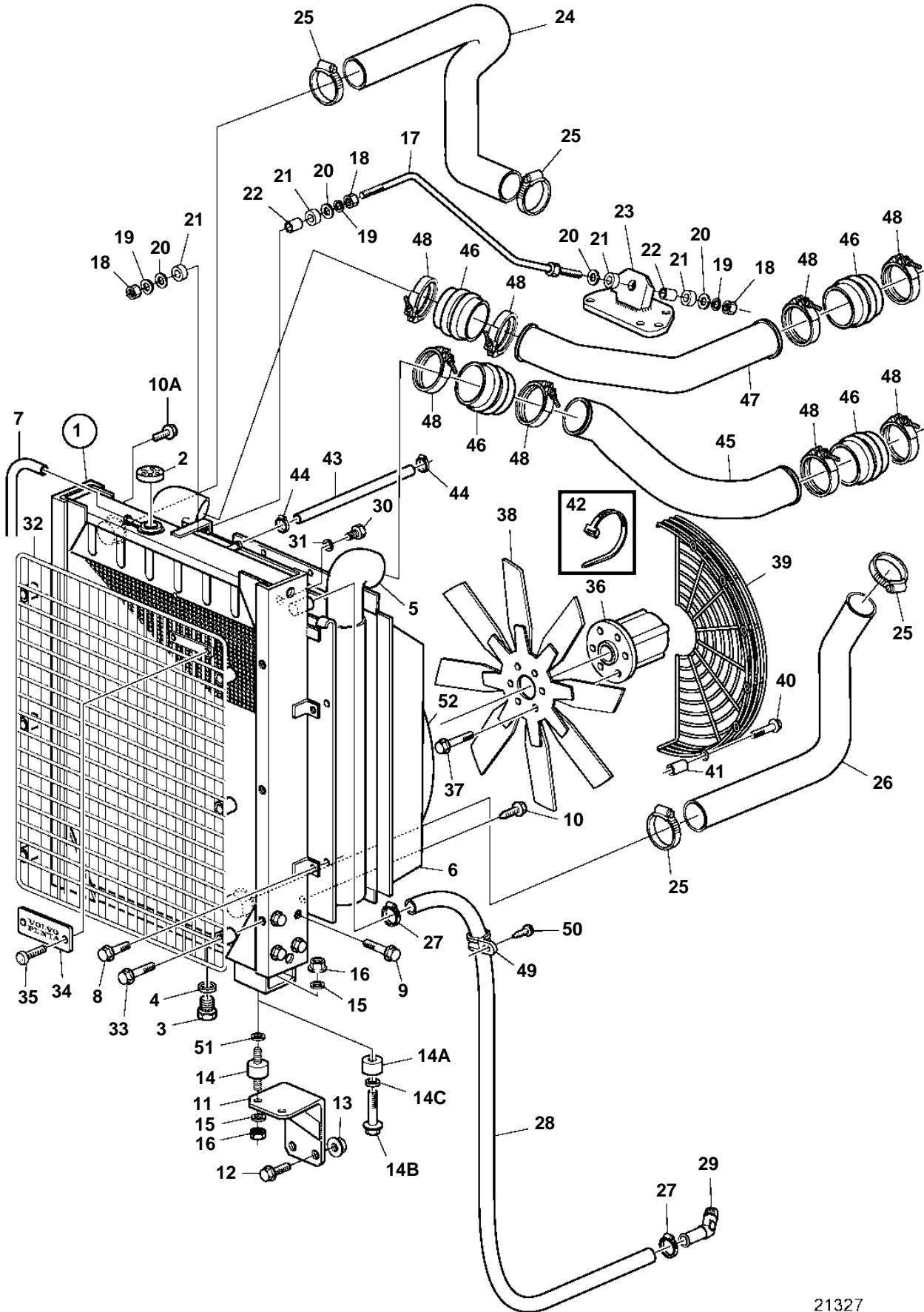

21327

TAD1230G, TAD1231GE, TAD1232GE

REF	PART NO.	QTY	DESCRIPTION	NOTES
1	866089	1	Radiator	REPL BY 3829280. 1,10m2.
	3829280	1	Radiator	
2	866095	1	• Pressure cap	
3	960630	1	Plug	
4	969011	1	Gasket	
5	866090	1	Intercooler	
6	3827830	1	Fan shroud	(3825747)
7	192618	X	Hose	L=1530mm
8	946173	4	Flange screw	
9	946441	8	Screw	
10	966862	2	Screw	
10A	967949	4	Screw	(965175)
11	865786	2	Anchorage	
12	946817	4	Screw	
13	971096	4	Nut	
14	849170	2	Rubber cushion	
14A	866856	2	Spacer	When rubber cushions are not used for the radiator.
14B	946502	4	Screw	When rubber cushions are not used for the radiator.
14C	940280	4	Spring washer	When rubber cushions are not used for the radiator.
15	940280	4	Spring washer	
16	955850	4	Nut	
17	865210	1	Anchorage	
18	955793	3	Nut	
19	941912	3	Spring washer	
20	948556	4	Washer	
21	941912	4	Spring washer	(866857)
22	252202	2	Bushing	
23	475888	1	Anchorage	
24	865194	1	Hose	
25	943480	4	Clamp	
26	865195	1	Hose	
27	943475	2	Hose clamp	
28	944386	X	Hose	L=900mm
29	942649	1	Nipple	
30	947660	1	Plug	
31	11994	1	Gasket	
32	865208	1	Radiator protector	
33	947760	6	Flange screw	
34	846118	1	Emblem	
35	941651	2	Screw	
36	865768	1	Fan hub	
37	946472	6	Screw	
38	848924	1	Fan, pusher type	
39	3825490	2	Fan protector	
40	945444	12	Flange screw	
41	946048	12	Spacer washer	
42	948211	10	Strip clamp	
43	943366	X	Hose	L=950mm (13776)
44	943470	2	Hose clamp	
45	865136	1	Pipe	
46	865127	4	Hose	
47	865137	1	Pipe	
48	865575	8	Hose clamp	
49	952637	1	Clamp	(943717)
50	945970	1	Screw	
51	191271	1	Washer	TH=6mm. To be mounted under the radiator, when spacer washer No. 3825890 is mounted between engine bracket and engine bed.
52	3827612	1	Fan ring	