

TD100G-87

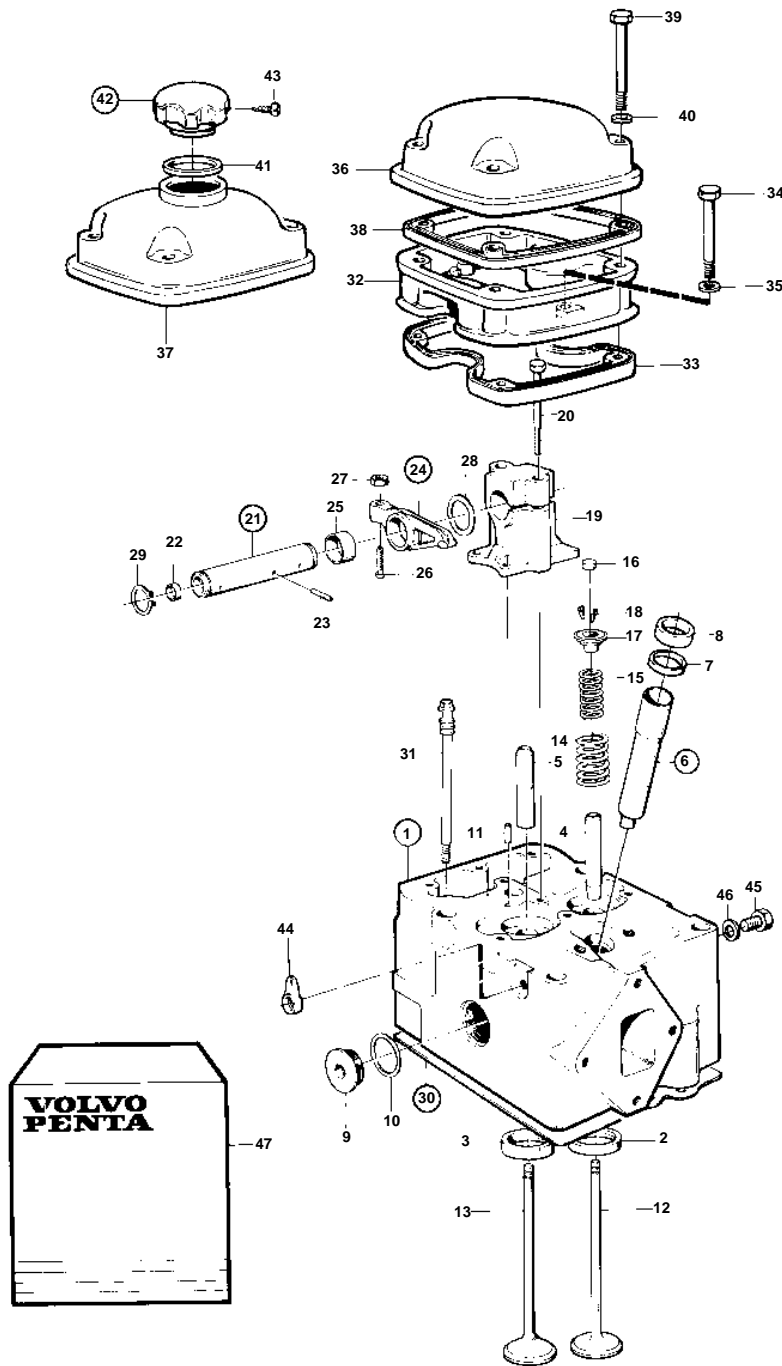

15006

## TD100G-87

REF	PART NO.	QTY	DESCRIPTION	NOTES
1	8194445	6	Cylinder head	
	3803039	6	Cylinder head, exch, exch	
2	467474	6	• Valve seat, intake	STD
	467590	6	• Valve seat, intake	O.S=0,20mm
3	1545886	6	• Valve seat, exhaust	STD
	1545885	6	• Valve seat, exhaust	O.S=0,20mm
4	422320	6	• Valve guide, intake	
5	11129092	6	• Valve guide, exhaust	(1545135)
6	270946	6	• Copper sleeve kit	
7	466405	6	• • Rubber ring	
8	466420	6	• • Steel ring	
9	8194467	12	• Plug	
10	949762	12	• O-ring	
11	950543	12	• Pin	
12	479204	6	Inlet valve, intake	
13	467855	6	Exhaust valve, exhaust	
14	467334	12	Valve spring	
15	467335	12	Valve spring	
16	478074	12	Valve cap	Included in gasket kit, decarbonizing 276035.
17	467506	12	Washer	
18	468305	24	Valve collet	
19	422018	6	Bearing bracket	
20	422428	12	Screw	
21	422019	6	Rocker arm shaft	
22	946778	12	• Cap plug	
23	950499	6	• Pin	
24	422063	12	Rocker arm	
25	422066	12	• Bushing	
26	422993	12	• Ball stud	
27	940175	12	• Nut	
28	941488	12	Washer	
29	914459	12	Lock ring	
30	270789	6		
		6	• Gasket	
	422415	12	• Sealing ring	I.D=17,5mm
	422414	12	• Sealing ring	I.D=31,5mm
	422413	6	• Sealing ring	I.D=10,5mm
31	422086	24	Flange screw	
32	469431	6	Valve cover	
33	424693	6	Gasket	Included in gasket kit, decarbonizing 276035.
34	940159	12	Screw	
35	955894	12	Washer	
36	469432	5	Valve cover	
37	469457	1	Valve cover, oil filling	
38	424694	6	Gasket	Included in gasket kit, decarbonizing 276035.
39	955530	24	Screw	
40	941907	24	Spring washer	Included in gasket kit, decarbonizing 276035.
41	1275379	1	Gasket	
42	421753	1	Oil filler cap	
43	955126	3	• Screw	
44	479260	6	Seal	Included in gasket kit, decarbonizing 276035.
45	941876	1	Plug	
46	18666	1	Gasket	
47	276035	1	De-carbonizing kit, decarbonizing	