

5.7GXi-F, 5.7GXi-FF, 5.7GXii-F, 5.7OSXi-D, 5.7OSXi-DF

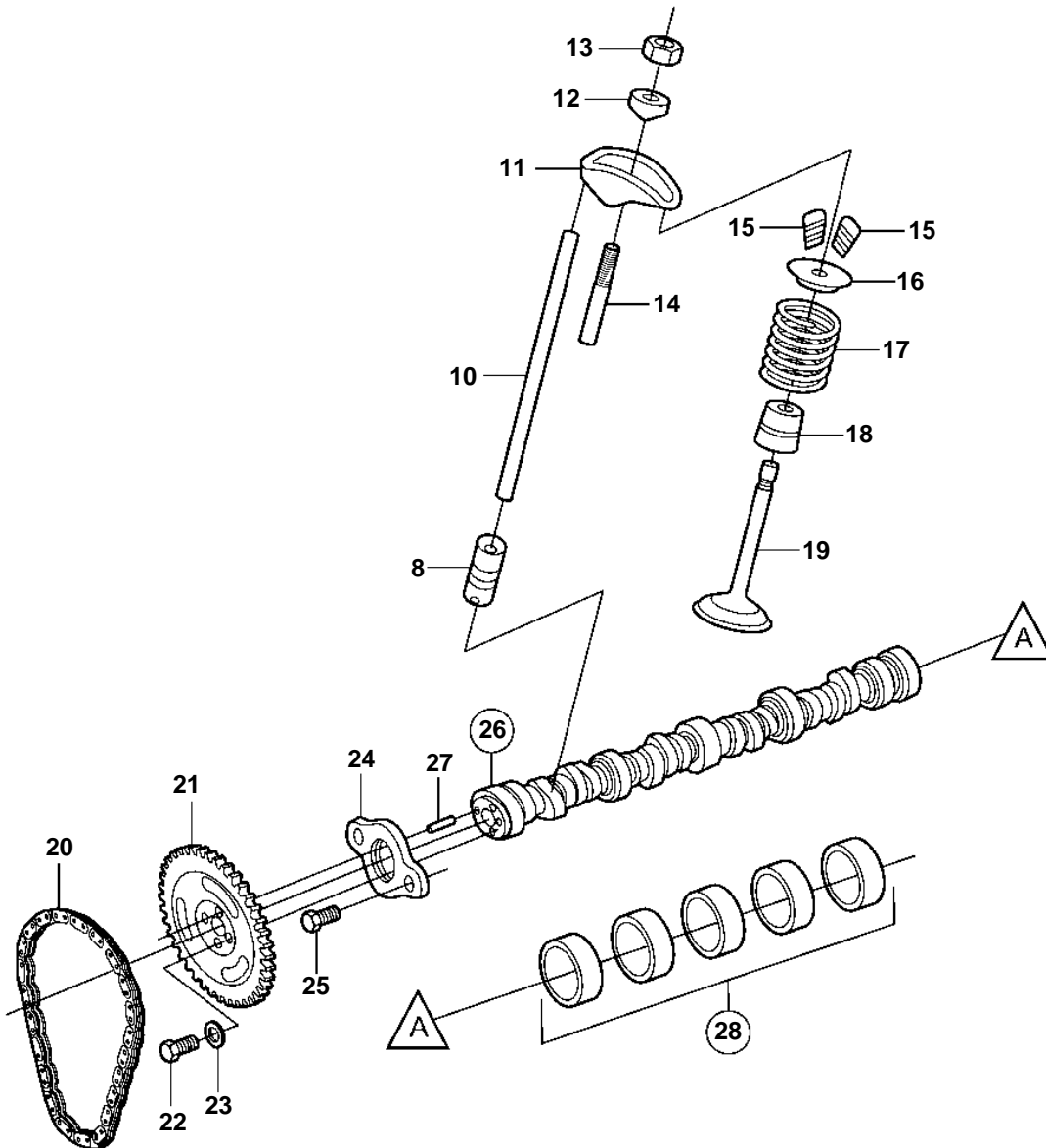
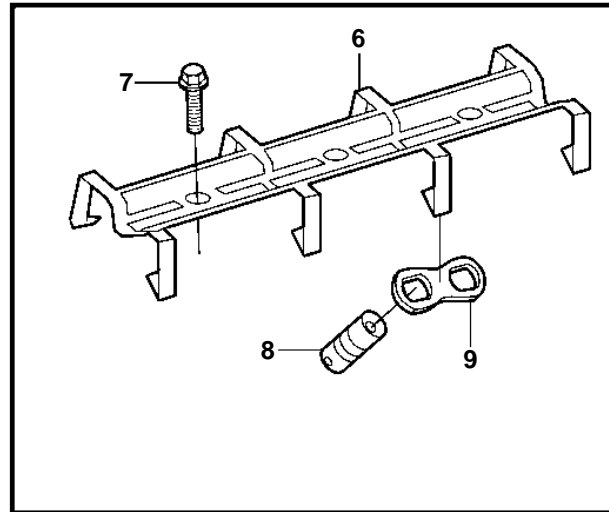
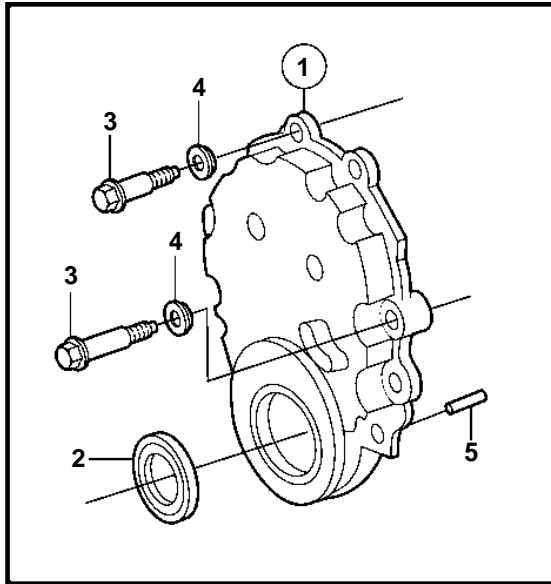

5.7GXi-F, 5.7GXi-FF, 5.7GXil-F, 5.7OSXi-D, 5.7OSXi-DF

REF	PART NO.	QTY	DESCRIPTION	NOTES
1	3862263	1	Timing gear cover	
		1	• Gasket	
2	3862262	1	• Sealing	
3	3855736	2	Screw	
	3855737	6	Screw	
4	3855739	8	Grommet	
5	3855972	2	Pin	
6	3856144	1	Retainer	
7		3	Bolt	
8	3856127	16	Tappet	
9	3856139	8	Guide	
10	3856118	16	Push rod	Replaced by 3863058, Earlier prod.
	3863058	16	Push rod	LATER PROD
11	3861167	1	Rocker arm, roller	Set
12		16	• Ball	
13		16	• Nut	
14	3853146	1	Stud	O.S=.003" (0.076mm)
		1	Stud	O.S=.013" (0.330mm)
15	3855823	32	Valve cotter	
16	3855816	16	Valve cap	
17	3855815	16	Valve spring	
18	3855814	8	Valve stem seal	Intake
	3862362	8	Valve stem seal	Exhaust
19	3855810	8	Valve, intake	Std
	3855808	8	Valve, exhaust	Std
20	3852685	1	Chain	
21	3856114	1	Sprocket	
22	3853173	3	Bolt	
23	3856151	3	Washer	
24	3855998	1	Retainer	
25	3853172	2	Screw	
26	3856119	1	Camshaft	
27	3855972	1	• Pin	
28	3856162	1	Kit	