

5.0GiC-J, 5.0GiC-JF, 5.0GXiC-J, 5.0GXiC-JF

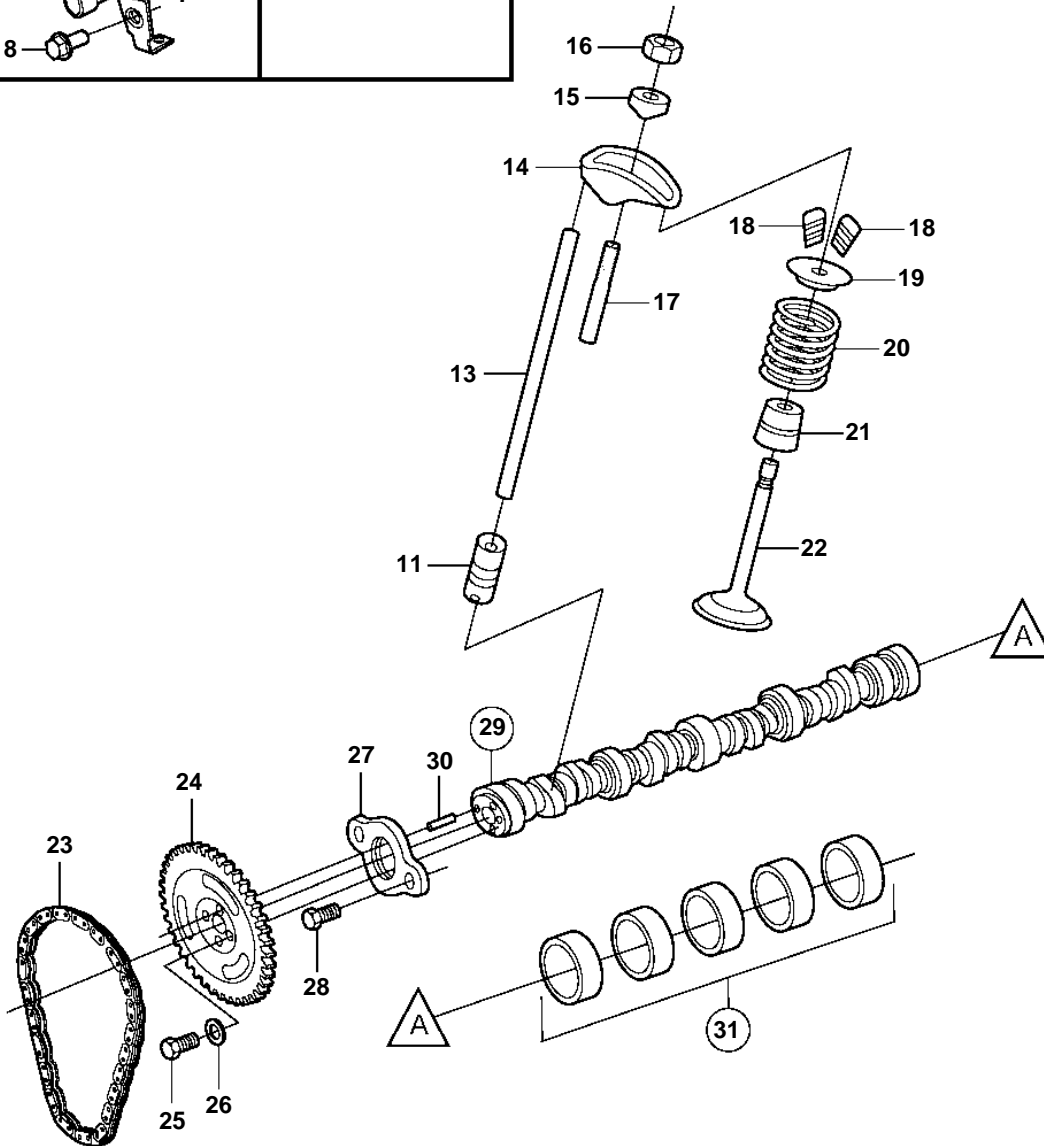
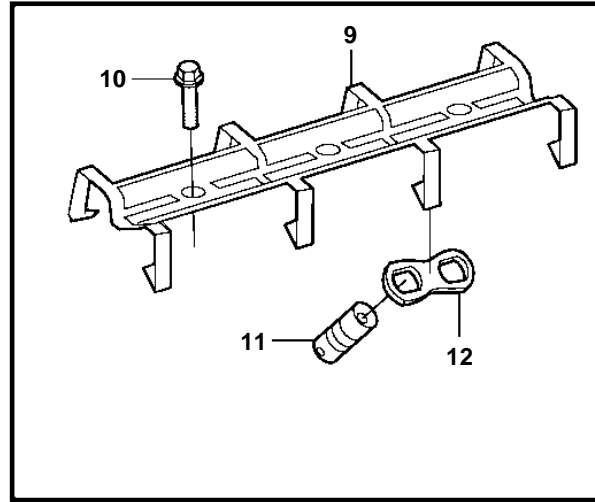
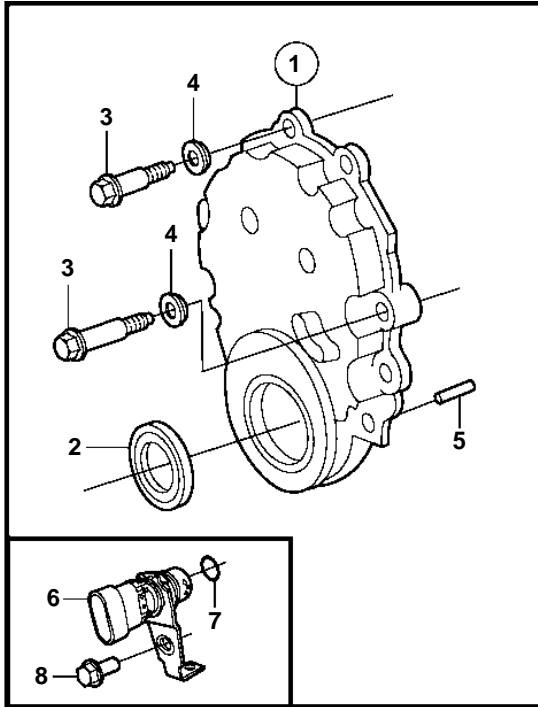

## 5.0GiC-J, 5.0GiC-JF, 5.0GXiC-J, 5.0GXiC-JF

REF	PART NO.	QTY	DESCRIPTION	NOTES
1	3862263	1	Timing gear cover	
		1	• Gasket	not sold separately
2	3862262	1	• Sealing	
3	3855736	2	Screw	
	3855737	6	Screw	
4	3855739	8	Grommet	
5	3855972	2	Pin	
6	3858979	1	Sensor	
7	3859009	1	O-ring	
8	3858983	1	Bolt	
9	3856144	1	Retainer	
10		3	Screw	Part not sold
11	3856127	16	Tappet	
12	3856139	8	Guide	
13	3856118	16	Push rod	Replaced by 3863058
	3863058	16	Push rod	
14	3853158	16	Arm	
15		16	• Ball	not sold separately
16		16	• Nut	not sold separately
17	3853146	1	Stud	O.S=.003" (0.076mm)
		1	Stud	O.S=.013" (0.330mm)
18	3855823	32	Valve cotter	
19	3855816	16	Valve cap	
20	3855815	16	Valve spring	
21	3855814	8	Valve stem seal	Intake
	3862362	8	Valve stem seal	Exhaust
22	3857666	8	Valve, intake	Standard
	3855808	8	Valve, exhaust	Standard
23	3852685	1	Chain	
24	3856114	1	Sprocket	
25	3853173	3	Bolt	
26	3856151	3	Washer	
27	3855998	1	Retainer	
28	3853172	2	Screw	
29	3856119	1	Camshaft	
30	3855972	1	• Pin	
31	3856162	1	Kit	