

4.3GL-P

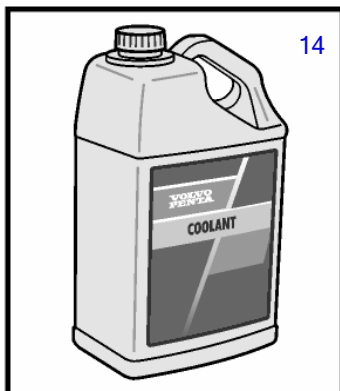
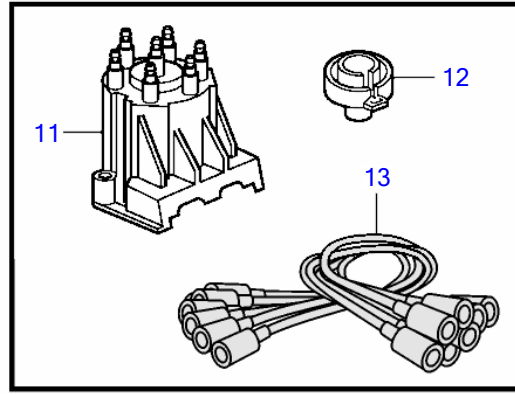
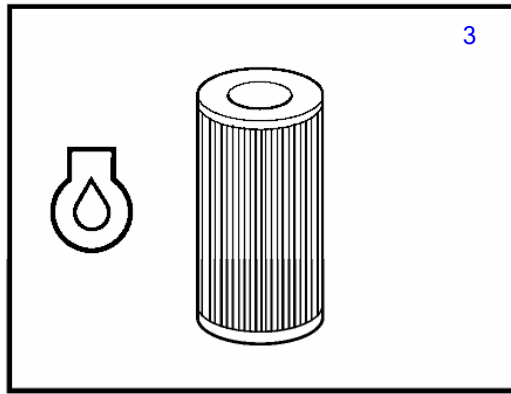
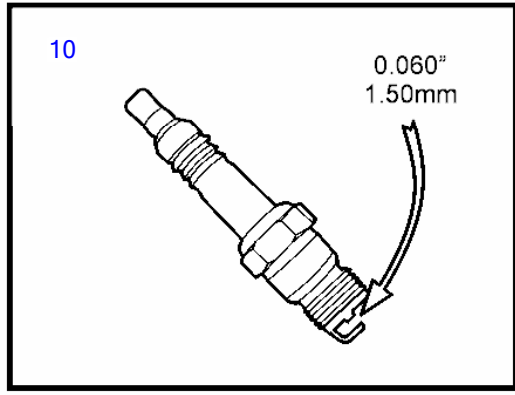
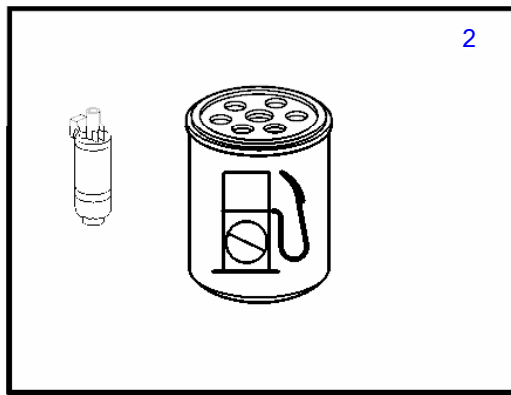
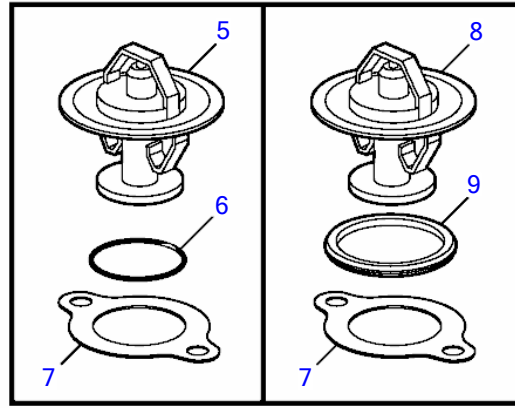
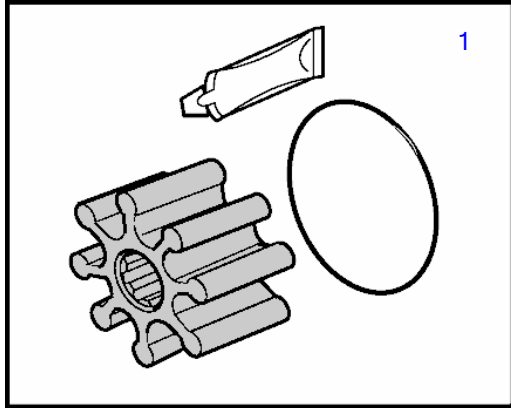

25136

4.3GL-P

REF	PART NO.	QTY	DESCRIPTION	SEE SEC.	NOTES
1	21213664	1	Impeller kit		
2	3862228	1	Fuel filter		
			• Bulletin P-23-3-4	P-23-3-4-EN	High Capacity Fuel Filter, Gas
			• Bulletin p-18-8-1	p-18-8-1-EN	Volvo Penta Ethanol Fuel treatment
3	8692305	1	Oil filter		
4		5	Oil		Fill level is determined by dipstick
		X			USA
	21681794	5	Oil		Synthetic, quart
			• Bulletin P-08-2-6	P-08-2-6-EN	Volvo Penta Oil Analysis for North America
4	21681795	1	Oil		Synthetic, gallon
	21681796	1	Oil		Synthetic, 5 gal
	21681797	1	Oil		Synthetic, 55 gal
	3847302	5	Oil		Mineral, quart
	3847303	1	Oil		Mineral, gallon
	3847304	1	Oil		Mineral, 5 gal
	3847305	1	Oil		Mineral, 55 gal
		X	Oil		Europe and other markets
	21363429	5	Oil		Premium, 1L
			• Bulletin P-18-3-5	P-18-3-5-EN	Oil Specification for Gas Engines
			• Bulletin P-18-3-6	P-18-3-6-EN	Gas Engine Oils Replaced
			• Bulletin P-08-2-6	P-08-2-6-EN	Volvo Penta Oil Analysis for North America
4	21363430	1	Oil		Premium, 5L
	21363431	1	Oil		Premium, 20L
5	3587597	1	Thermostat		For seawater cooled engine
6	983944	1	O-ring		
7	3852111	1	Gasket		
8	3831426	1	Thermostat kit		For freshwater cooled engine
9	416033	1	• Sealing ring		
10	21513423	1	Spark plug kit		
11	3854331	1	Distributor cap		
12	3854311	1	Rotor		
13	3888325	1	Ignition cable kit		
14	1141674	1	Coolant, green		5L, ready-mixed
			• Bulletin P-18-4-4	P-18-4-4-EN	Coolant Recommendations for Gas Engines
			• Bulletin P-18-4-7	P-18-4-7-EN	Coolant P/Ns Changed, US Only
			• Bulletin P-18-4-3-02	P-18-4-3-02-EN	Important Information about Volvo Penta Coolant
14	21646481	1	Coolant, green		210L, ready-mixed
			• Bulletin P-18-4-3-02	P-18-4-3-02-EN	Important Information about Volvo Penta Coolant
14	1141647	1	Coolant, green		210L, full strength
			• Bulletin P-18-4-3-02	P-18-4-3-02-EN	Important Information about Volvo Penta Coolant