

TAMD61A

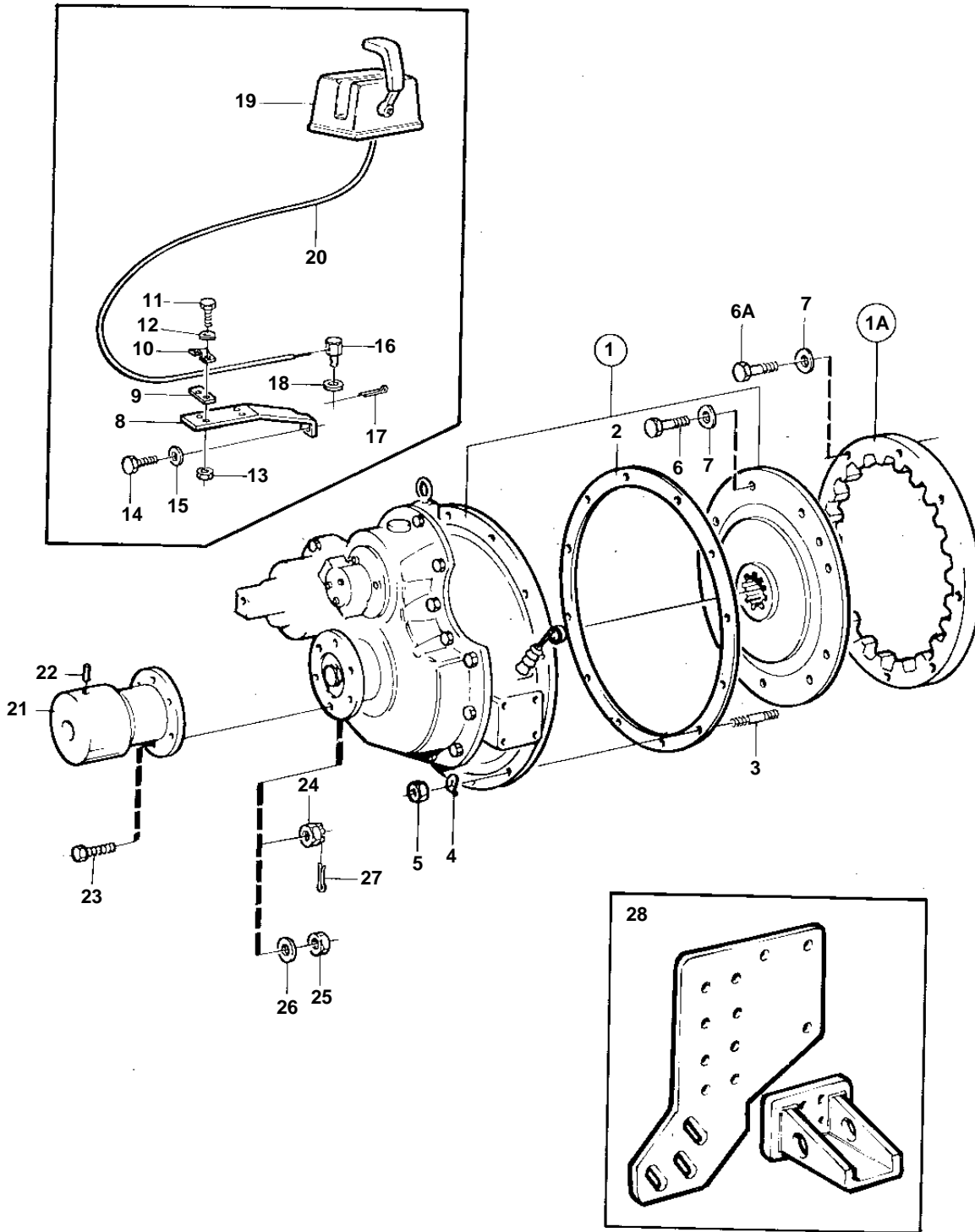

15949

TAMD61A

REF	PART NO.	QTY	DESCRIPTION	NOTES
1		1	Reversing gear Comps. not spec.	RATIO -2.99:1
1A		1	Drive ring Comps. not spec.	EARLY TYPE
2	862623	1	Gasket	
3	953486	11	Stud	
4	942336	11	Spring washer	
5	955827	11	Nut	
6	940114	8	Screw	
6A	956582	8	Screw	
7	942336	8	Spring washer	
8	863483	1	Bracket	
9	819068	1	Washer	
10	819067	1	Brace	For control cable 333, 33c.
	6853782	1	Clamp	For control cable 443, 43c.
11	956079	2	Screw	
12	941905	2	Spring washer	EARLIER PROD, TAMD71A
13	963104	2	Nut	
14	970948	1	Screw	
15	941908	1	Spring washer	
16	853217	1	Cube	
17	17253	1	Cotter pin	
18	940191	1	Washer	
19		X	Control	SEE GROUP 27
20		X	Control cable	SEE GROUP 27
21	842106	1	Clutch flange	For reverse gear RATIO -1.98:1.
	865434	1	Clutch flange	SO For reverse gear RATIO 2.98:1-.
22	965011	2	Pin	SO For reverse gear RATIO 2.98:1-.
23	955738	6	Screw	L =57mm, EARLY TYPE. For reverse gear RATIO -1.98:1.
	955739	6	Screw	L = 64mm, LATE TYPE. For reverse gear RATIO -1.98:1.
		6	Screw	L =57mm, EARLY TYPE. For reverse gear RATIO 2.98:1-.
	955751	6	Screw	SO L = 64mm, LATE TYPE. For reverse gear RATIO 2.98:1-.
24	955886	6	Nut	EARLY TYPE. For reverse gear RATIO -1.98:1.
	955887	6	Nut	FOR 955750. For reverse gear RATIO 2.98:1-.
	950379	6	Nut	FOR 955751. For reverse gear RATIO 2.98:1-.
25	950378	6	Nut	LATE TYPE. For reverse gear RATIO -1.98:1.
26	941912	6	Spring washer	LATE TYPE. For reverse gear RATIO -1.98:1.
	941914	6	Spring washer	LATE TYPE. For reverse gear RATIO 2.98:1-.
27	907861	6	Cotter pin	EARLY TYPE. For reverse gear RATIO 2.98:1-.
28		2	Engine suspension	SEE GROUP 21