

KAD42A, KAMD42A

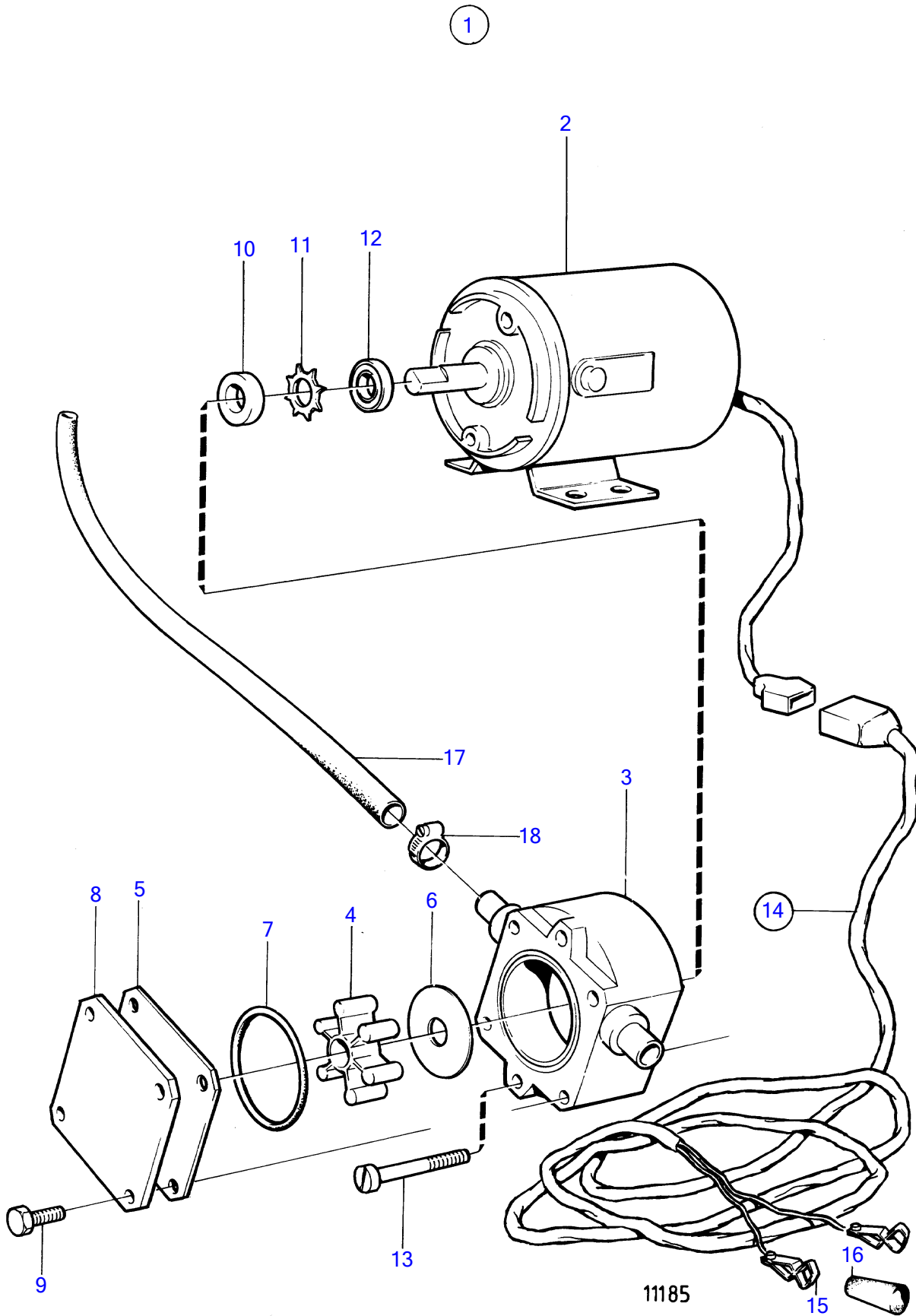

KAD42A, KAMD42A

REF	PART NO.	QTY	DESCRIPTION	NOTES
1	843114	1	Oil bilge pump	12V
2		1	• el. motor	12V
3	(844015)	1	• • Pump housing	Obsolete part
4	844022	1	• • Impeller kit, impeller	
5	844017	1	• • Wear washer	
6	844016	1	• • Wear washer	
7		1	• • o-ring	
8	844018	1	• • Cardboard tube	
9	844021	4	• • Screw	
10		1	• • seal ring	
11		1	• • lock washer	
12	844019	1	• • Deflector ring	
13	847464	2	• • Screw	
14	843113	1	• Cable trunk	
15		1	• • battery terminal	Replaced by 1ea 844280,1ea 844278, +
		1	• • battery terminal	Replaced by 1ea 844280,1ea 844279
	844280	2	• • Clip	Late type
16	(844279)	1	• • Isolation	Late type black, Obsolete part
	(844278)	1	• • Isolation	Late type red, Obsolete part
17	943707	X	• Hose	12X4X3000mm
18	943471	3	• Hose clamp, hose clamp	