

KAD42A, KAMD42A

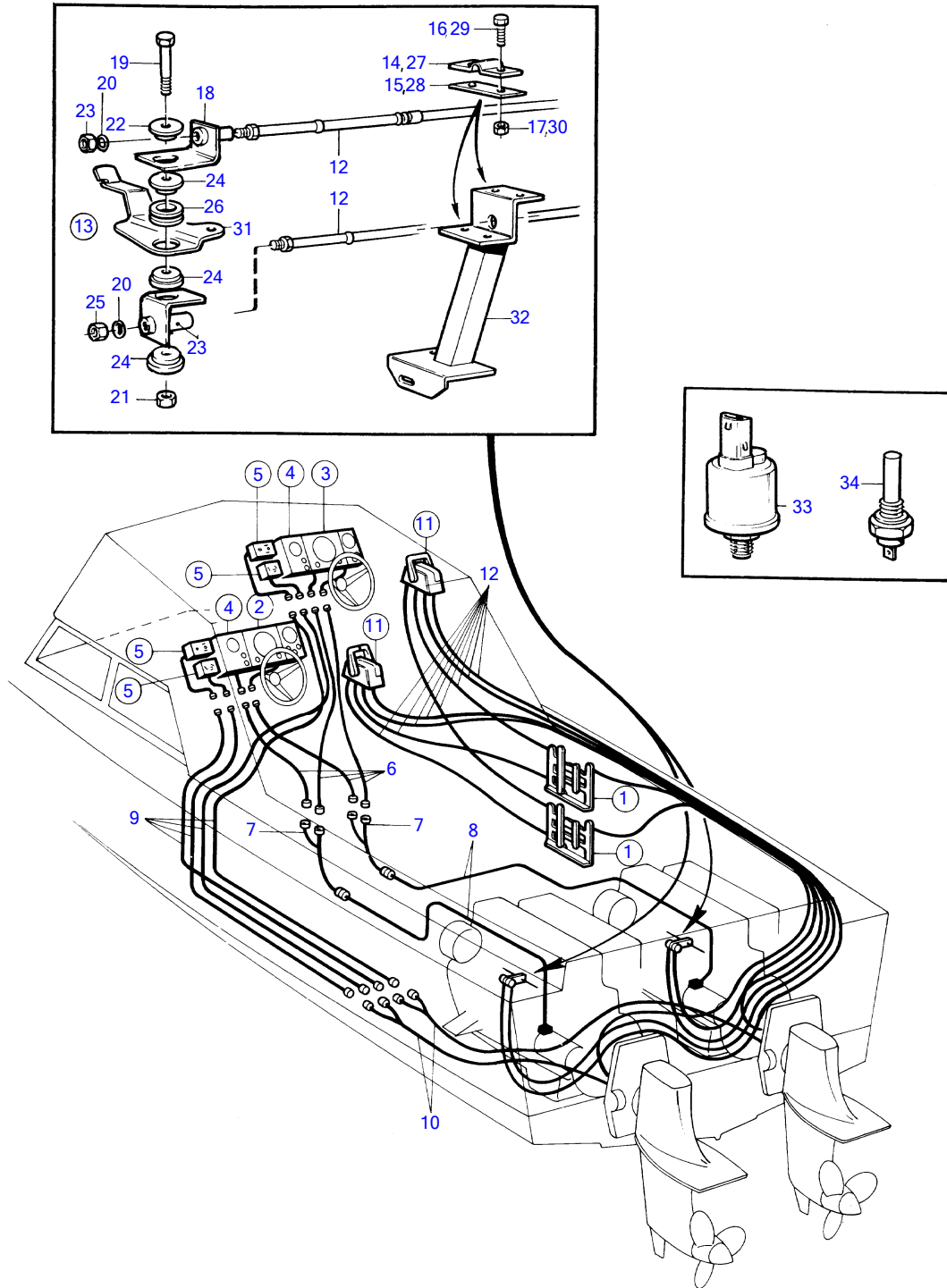

11081

KAD42A, KAMD42A

REF	PART NO.	QTY	DESCRIPTION	SEE SEC.	NOTES
1	828164	2	Connection plate		
			•	20770	
2		2	instrument panel		Std, see group 3
3	864043	2	Instrument panel		
			•	20774	
4	(858874)	X	Instrument panel		Obsolete part
			•	20776	
5		4	trimmer		See group 4A
6	846648	X	Extension cable'verl		L=3000mm
	846649	X	Extension cable'verl		L=5000mm
	846650	X	Extension cable'verl		L=7000mm
7	1140598	2	Distributing contact		
8		2	cable unit		Std, see group 3
9	853052	X	Extension cable'verl		L=3000mm
10		2	cable unit		
		X	• cables and terminals		See group 3
11		X	control		
12		X	control cable	20771	
13	861221	2	Engine speed control		
14	21471054	2	• Bracket		
15	819068	2	• Washer		
16	956078	4	• Cross recessed screw		
17	951674	4	• Lock nut		
18	861215	2	• Bracket		
19	955275	2	• Hexagon screw		
20	955971	4	• O-ring		
21	946035	2	• Lock nut		
22	843105	2	• Spacer washer		
23	861214	2	• Bracket		
24	843105	6	Spacer washer		
25	951674	4	Lock nut		
26	843109	2	Bushing		
27	21471054	2	Bracket		
28	819068	2	Washer		
29	956078	4	Cross recessed screw		
30	951674	4	Lock nut		
31		1	bracket		See group 2D
32		1	bracket		See group 2D
33	862568	2	Oil pressure sensor		
34	840074	2	Temperature sensor		