

D12D-A MG

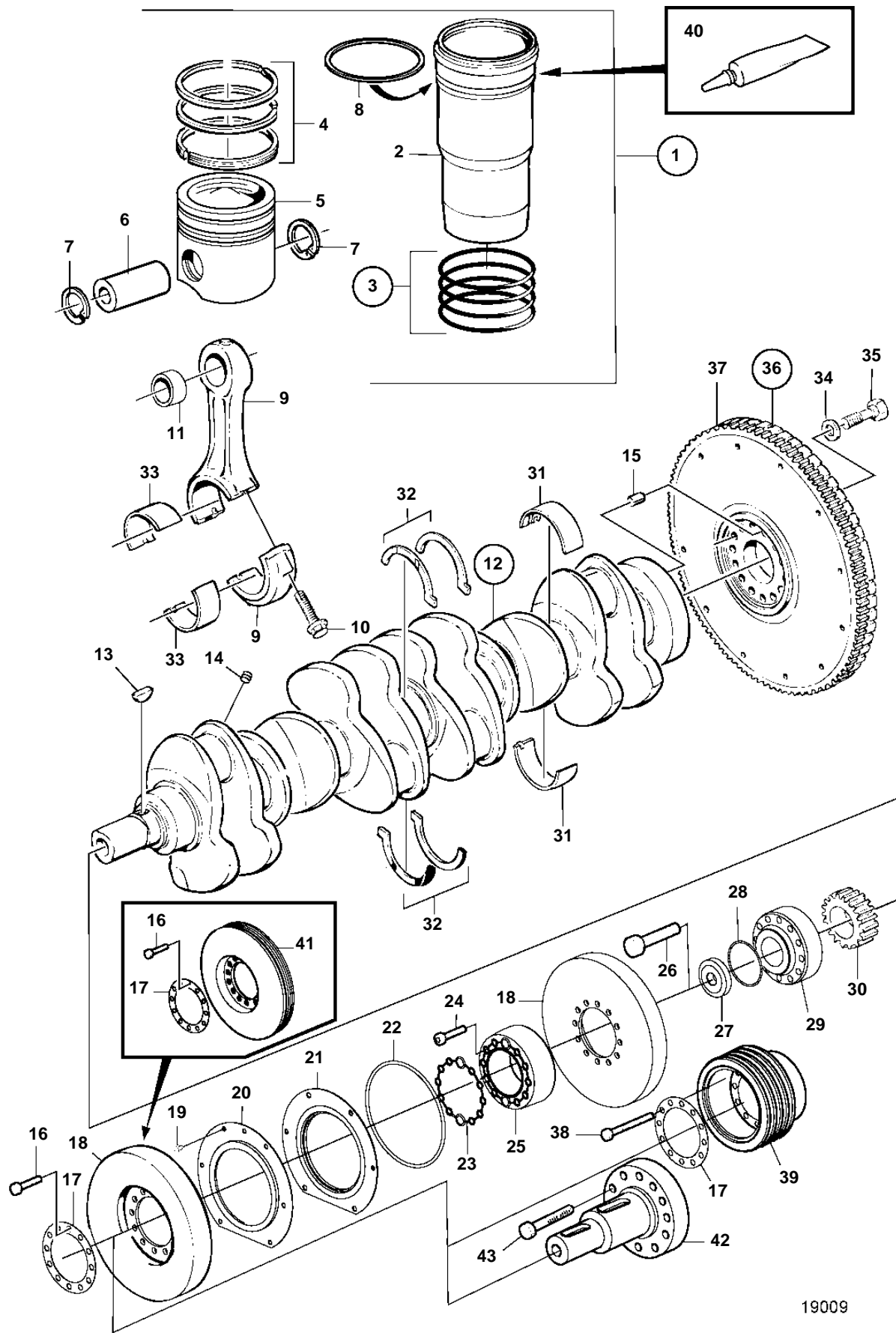

19009

## D12D-A MG

REF	PART NO.	QTY	DESCRIPTION	NOTES
1	877574	6	Cylinder liner kit	Replaced by overhaul kit 21223179, contains 6 pcs cylinderfodersatser 21223179 and 6pcs connecting rod
2		1	· Cylinder liner	
3	270950	1	· Sealing kit	
4	3840819	1	· Piston ring kit	Replaced by 3848522
	3848522	1	· Piston ring kit	
5		1	· Piston	
6	3155115	1	· Piston pin	
7	914530	2	· Snap ring	
8	1677592	6	Shim	TH = 0.30mm
	1677593	6	Shim	TH=0.50mm
	1677591	6	Shim	TH = 0.20mm
9	3835339	6	Connecting rod	(3184823)
10	1543035	12	· Screw	
11	20381185	6	· Bushing	(470304)
12	20538850	1	Crankshaft	(3832928)
13	422253	1	· Woodruff key	
14	978130	6	· Plug	
15	950645	1	· Pin	
16	963254	10	Hexagon screw	
17	8193962	1	Washer	
18	8193930	2	Vibration damper	
19	946440	6	Flange screw	
20	3827504	1	Dust cover	
21	3832863	1	Sealing ring	
22	3832906	1	O-ring	
23	3827530	1	Sealing ring	
24	974111	2	Hex. socket screw	
25	3826656	1	Companion flange	
26	1543316	1	Screw	
27	422124	1	Washer	
28	945512	1	O-ring	
29	1549407	1	Hub	
30	8170192	1	Gear	
31	20530916	7	Main bearing	Std, (276615)
		7	· Bearing shell, upper	Marked 20530902
		7	· Bearing shell, lower	Marked 20530900
	20578624	7	Main bearing	U.S=0.25mm, (276616)
		7	· Bearing shell, upper	Marked 20578619
		7	· Bearing shell, lower	Marked 20578613
	20578625	7	Main bearing	U.S=0.50mm, (276617)
		7	· Bearing shell, upper	Marked 20578620
		7	· Bearing shell, lower	Marked 20578614
		7	Main bearing	U.S=0.75mm, (276618)
		7	· Bearing shell, upper	Marked 20578621
		7	· Bearing shell, lower	Marked 20578615
	20578627	7	Main bearing	U.S=1.00mm, (276619)
		7	· Bearing shell, upper	Marked 20578622
		7	· Bearing shell, lower	Marked 20578616
		7	Main bearing	U.S=1.25mm, (276620)
		7	· Bearing shell, upper	Marked 20578623
		7	· Bearing shell, lower	Marked 20578617
32	3093651	1	Thrust washer	Std
	3093652	1	Thrust washer	TH = 0.10mm
	3093653	1	Thrust washer	TH = 0.20mm
33	276134	6	Big-end bearing shel	Std
	276135	6	Big-end bearing shel	U.S=0.25mm
	276136	6	Big-end bearing shel	U.S=0.50mm
	276137	6	Big-end bearing shel	U.S=0.75mm
	276334	6	Big-end bearing shel	U.S=1.00mm
		6	Big-end bearing shel	U.S=1.25mm
34	1543563	14	Washer	
35	1677893	14	Screw	

## D12D-A MG

REF	PART NO.	QTY	DESCRIPTION	NOTES
36	3841339	1	Flywheel	(866380)
37	20711957	1	• Ring gear	(8193939)
38	970893	10	Hexagon screw	
39	3826648	1	V-belt pulley	
40	1161231	X	Sealant	304ml
	1161277	X	Sealant	20g
41	11127304	1	Pulley	Pulley for fan drive, D12D-A MG, ALT
42	3831617	1	Stub axle	ALT
43	970891	10	Hexagon screw	For drive shaft 3831617