

\$24.95

# Product Knowledge Handbook

January 2012

**MERCURY**  
MerCruiser

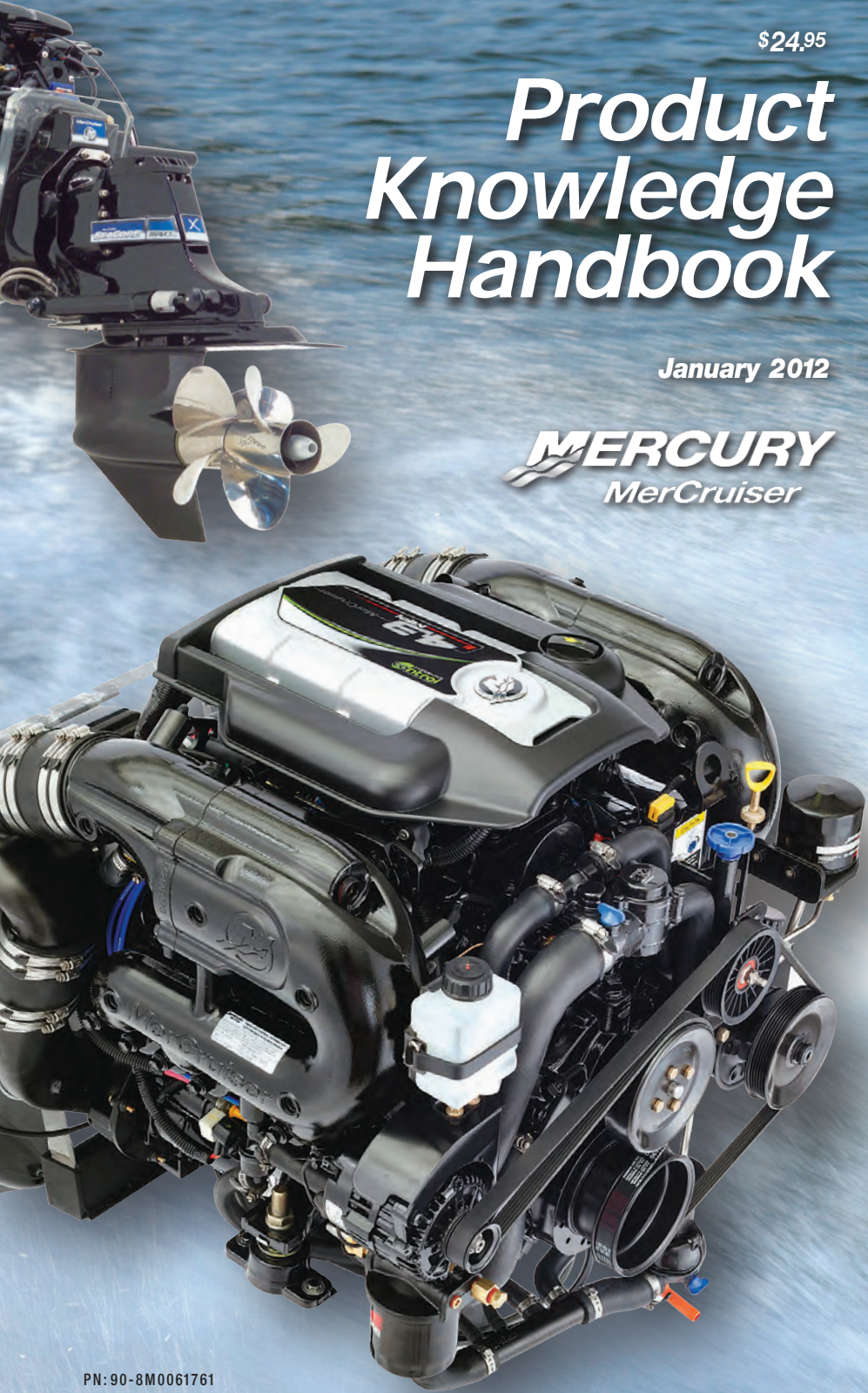

PN:90-8M0061761



## Table of Contents

Enhancing The Ownership Experience .....	2	Axius .....	16-23
The Mercury Advantage.....	3	SeaCore .....	24-27
Warranty Information .....	4~5	Sterndrive Engines .....	28-59
Product Term Glossary .....	6~11	Drives .....	60-85
Emission Control Technology....	12~15		

### QUALITY POLICY

WE AT MERCURY, WILL STRIVE TO UNDERSTAND  
OUR CUSTOMERS' REQUIREMENTS.

THROUGH THE USE OF SYSTEMATIC PROCESSES  
WE WILL DRIVE CONTINUAL IMPROVEMENT  
IN THE DESIGN, MANUFACTURE, AND DELIVERY  
OF OUR PRODUCTS AND SERVICES SO THAT  
WE WILL CONSISTENTLY EXCEED OUR  
CUSTOMER'S EXPECTATIONS.

# Enhancing The Ownership Experience

**The MerCruiser Ownership Experience** begins the moment the customer enters your dealership, and continues well beyond the warranty period or service maintenance schedule.

Today's boat owners are increasingly aware that **higher technology engines deliver** a superior overall boating experience. Though it's something our customers rarely see, no other part of their boat has more influence on the ownership experience. In fact, the right choice can deliver the power and performance they crave, the safety and peace of mind they need and all the innovative technologies that make piloting simple and intuitive. **MerCruiser is the right choice.**

Good, value-priced, reliable products are not enough to satisfy today's buyers. It takes a commitment to customer and improving the ownership experience to **keep loyal customer coming back.**



# *The Mercury Advantage*

**Today's consumers** have done their research via web-site, catalogs and are loaded with more information and questions as they consider a product purchase.

One of our most powerful sales tools is **product knowledge**. The information in this handbook is designed to further enhance your knowledge about Mercury products. This guide provides an arsenal of in-depth specifications, key features, customer benefits and **Mercury's many strengths** to utilize when selling against the competition.

After qualifying your customers expectations, we recommend picking **5 Key Features/Benefits** that establish quality, add value, that meet the customer's wants and needs.

*We hope  
you find this  
Product  
Knowledge  
Handbook  
informative  
& helpful.*

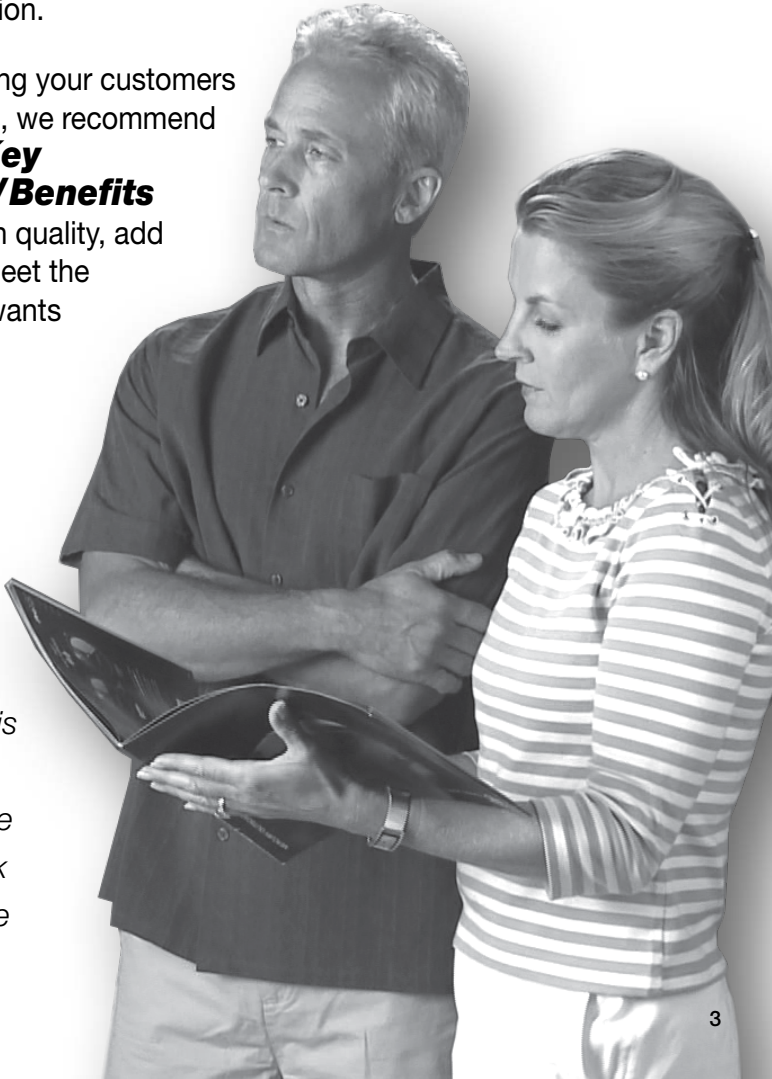

# Warranty Information



**IQ Certified**

## Installation Quality Certification

This rigorous program not only sets new industry standards for manufacturing and quality control, but rewards certified builders with an extra year of factory-backed limited warranty\*\* coverage on all MerCruiser powered boats.

\*\*For engine registrations outside the United States and Canada, local market warranty length will apply and in no case will this be less than two years for certified boat brands.

<b>MerCruiser</b>		
<b>Models</b>	<b>Standard Limited Warranty</b>	<b>With I.Q. Certification</b>
<b>S T E R N D R I V E S</b>		
<b>STANDARD MODELS</b> 3.0, 4.3, 5.0, 350 MAG, 377 MAG, 8.2 MAG, 8.2 MAG HO	1 -Year Limited	2 -Year Limited
	3 -Year Limited Corrosion	3 -Year Limited Corrosion
<b>SEACORE MODELS</b> 4.3, 5.0, 350 MAG, 377 MAG, 8.2 MAG, 8.2 MAG HO	3 -Year Limited	4 -Year Limited
	4 -Year Limited Corrosion	4 -Year Limited Corrosion
<b>I N B O A R D</b>		
<b>STANDARD MODELS</b> 8.2 HO (425HP) DTS	1 -Year Limited	2 -Year Limited
	3 -Year Limited Corrosion	3 -Year Limited Corrosion
<b>HORIZON MODELS</b> 5.7 HORIZON DTS, 6.2 HORIZON DTS, 8.2 HORIZON (375hp) DTS	3 -Year Limited	4 -Year Limited
	3 -Year Limited Corrosion	3 -Year Limited Corrosion
<b>T O W S P O R T S *</b>		
5.7 MPI, SCORPION 350 DTS	2 -Year Limited	3 -Year Limited
	3 -Year Limited Corrosion	3 -Year Limited Corrosion

\* Above Tow Sports engines manufactured after January 1, 2008

<b>Mercury Racing Sterndrives</b>	
<b>Models</b>	<b>Standard Limited Warranty</b>
525 EFI, 600 SCi	1 -Year Limited
	3 -Year Limited Corrosion*
662 SCi, 700 SCi	1 -Year Limited
	No Corrosion Warranty
1100	1 -Year Limited
	No Corrosion Warranty
1350	1 -Year Limited
	No Corrosion Warranty

\* No corrosion warranty with models equipped with NXT1 or NXT1 SSM Drives

# Warranty Information

## Emission Control System *Limited Warranty*

### California Emission Control Warranty

Specific emission control related parts on new inboard or sterndrive engines are warranted for 3 years or 480 hours, whichever first occurs, from either the date the product is first sold.

### U.S. EPA Emissions Limited Warranty

Consistent with the obligations created by 40 CFR Part 1045, Subpart B, Mercury Marine provides an emission warranty of three years or 480 hours of engine use whichever occurs first to the retail purchaser.

### Emission Control System Components

The emission related warranty covers all components whose failure would increase an engine's emission of any regulated component including the following list of components:

- 1. Fuel Metering System**
- 2. Air Induction System**
- 3. Ignition System**
- 4. Lubrication System**
- 5. Positive Crankcase Ventilation (PVC) System**
- 6. Exhaust System**
- 7. Catalysts or Thermal Reactor System**
- 8. Miscellaneous Items Used in Above Systems**

For more details, please refer to the California Emission Limited Warranty PDF Part # 90-8M0048405 JULY 2010 or go online to [www.mercurymarine.com](http://www.mercurymarine.com)

# Product Term Glossary

## A

**Air-Actuated Drain** – A single point drain system that uses air pressure to open a pair of pneumatic valves that drain the engine of raw water to prevent freeze damage during storage or transport. This is standard with FWC on new MPI engines.

**Alpha Drive** – A small, light sterndrive system designed for up to 300 horsepower applications. It competes in a cost-effective manner for a large variety of applications. Opposite rotation is available as an option. The floppy vane water pump that feeds the engine is located in the Alpha drive.

**Autosynch** – DTS synchronizes multiple engines above idle speeds for the ultimate in control and ease of setting cruise speeds. It automatically deactivates over 95% throttle and when the throttles are more than 5% apart.

## B

**Ball-Joint Controls** – A quick-connect throttle and shift linkage for use on Tow Sport engine models to accommodate fine adjustments to the linkage for custom throttle feel.

**Big Block** – A MerCruiser V8 engine design that has larger bore centers and a taller deck height than a small block. Common big block displacements are: 7.4L, 8.1L, 8.2L .

**Braided Stainless Steel Trim Cylinder Hoses:** Used on stern drive unit to prevent corrosion and damage from foreign objects and animals.

**Bravo One Drive** – This sterndrive system is designed for up to 400 horsepower applications. It has a dual water pick-up that allows up to 17 X-Dimensions to be used. Twin applications are typical for performance boats. The drive is fully reversible.

**Bravo One X, Two X, Three X Drive** – Typically used on diesel product to with higher strength internal components to handle the higher torque requirements of diesel engines. Now also used on product to handle power up to 450 horsepower.

**Bravo Three Drive** – This sterndrive system is designed for low slip and high lift for increased speeds by using two counter-rotating propellers up to 400 horsepower. It so provides an extremely stable boat ride with the ability to steer in reverse equally well in either direction. This is the most versatile and popular Bravo drive. The drive is fully reversible.

**Bravo Two Drive** – This sterndrive system is designed for high thrust at low speeds for large boats traveling less than 55 mph. The strut area is longer to allow the use of a large prop. It is designed for up to 400 horsepower applications. In large boat twin engine applications, it could be a wiser choice than Bravo Three Drives because only one prop per drive is used and more thrust is delivered. The drive is fully reversible.

**Bravo XR Drive** – This drive is built for factory-class racing. It is machined and assembled with premium racing components for use up to 600 horsepower as a Bravo One XR, or 525 Horsepower as a Bravo Three XR.

## C

**Circulating Pump** – A water pump mounted to the block to circulate coolant through the block and heads.

**Closed Cooling System:** Closed Cooling System Also called Fresh Water Cooling. A cooling system that uses an anti-freeze mixture to cool the block, heads and sometimes exhaust manifolds. This coolant passes through a heat exchanger cooled by raw seawater. This is commonly used in salt water to prevent corrosion damage.

# Product Term Glossary

**Compact Hydraulic Steering (CHS) Optional Kit-** A sterndrive steering option to replace the power steering system with a non-power hydraulic steering system for saving space in the engine compartment. This is typically used for pontoon and houseboat applications.

**Cone Clutch:** A “V” or cone-shaped clutch designed to transfer the crankshaft motion of the engine without the need for a hydraulic type transmission. A steel cone clutch is standard on Bravo Series from MerCruiser.

**Cool Fuel System** – The patented fuel delivery system used for fuel-injected engines to deliver high-pressure fuel to the engine. It utilizes water-cooling, insulation, and low-mounting to prevent fuel from overheating and the engine vapor locking.

## D

**Digital Throttle & Shift (DTS)** – An option available on some product that controls shifting and throttle position directly through the engine controller without the use of push-pull cables. This has the advantage of smooth, clunk-free and ratchet-free shifting, as well as, superior throttle feel and response. There are also benefits to eliminate cable maintenance and ease of installation to improve reliability. Another feature is automatic engine synchronization.

**Down Angle Transmission** – A Transmission with a built-in 8 degree down angle from the engine crankshaft. With the 8 degrees built into the output flange, it allows for engines to be moved further back and uses a shorter propshaft than a in-line transmission.

**Dry-Joint Exhaust** – A robust design that completely separates cooling water and exhaust at junctions to prevent water leaks.

**Dual Dipsticks** – A feature on some inboard engines that allows the engine crankcase oil to be checked from either the starboard or port side of the engine.

**DWP – Dual Water Pickup** – Used on Bravo One, One X & One XR drives. Water enters the drive at both the leading edge of the torpedo housing and the sides. This allows the use of up to 17 X-Dimensions while insuring continuous water flow because it self-purges debris.

## E

**Easy Oil Drain** – A system that allows oil to be drained from the bottom of the oil pan through a hose. It pulls through a drain hole in the transom or bottom of the boat.

**ECM** – A digital engine control module used to control fuel injection, spark management, and Smart Craft.

**EDP** – Electrode Deposition Paint. Paint applied through immersion in paint with an electrostatic charge to create an outstanding bond to a metal's surface for barrier protection against corrosion.

**Engine Coupler** – Device used to couple the engine to the sterndrive unit. The rubber hub design helps absorb vibrations and dampen shift engagement. It is the flexible coupling between the engine crankshaft and sterndrive unit.

**Engine Drive Plate** – The device used to couple a transmission to the engine crankshaft. The design could be a dual stage spring plate style or one with synthetic material. The drive plate is designed to minimize drivetrain noise.

**Engine Guardian** – A strategy used to protect the engine from conditions that could damage the engine and leave the boater stranded. Various engine functions are monitored and power is reduced accordingly to protect the engine if conditions warrant. Guardian is activated for the following: Engine coolant high, Engine oil pressure low, Engine speed high, Drive lubricant level low, Seawater pressure low, Battery voltage low, Exhaust manifold temperature high (aluminum manifold only)

# Product Term Glossary

**Exhaust Bellows** – A corrugated rubber tube through which exhaust exits the transom assembly providing quieter operation.

**Exhaust Risers** – Spacers used to raise the height of the exhaust outlets above the boat's waterline to prevent water damage.

**Exhaust Tubes** – A smooth-wall rubber tube through which exhaust exits the transom assembly. This lowers restriction for higher exhaust flow and more power.

## F

**Flush Port** – A water port that connects a water hose to an engine's water supply in order to flush salt water out of the engine's water passages to prevent corrosion.

**4-stroke** – An engine that completes its cycle in two crankshaft revolutions. These are characterized by low emissions, low fuel consumption, and high power generation.

**Fresh Water Cooling (Closed Cooling)** – A cooling system that uses an anti-freeze mixture to cool the block, heads and sometimes exhaust manifolds. This coolant passes through a heat exchanger cooled by raw seawater. This is commonly used in salt water to prevent corrosion damage.

**FWC Kit** – A kit to add Fresh Water Cooling if not factory installed.

## G

**Gear Lube Reservoir** – A clear bottle mounted on the engine that shows the level of drive gear lube. A float sensor is in the reservoir that will sound a horn if the level is too low.

## H

**Heat Exchanger** – A copper shell and tube assembly that conducts heat between sea water and engine coolant. Long-life anti-freeze flows through the block, heads and sometimes exhaust manifolds. Corrosive sea water flows only through the corrosion resistant copper heat exchanger, other coolers, and then out the exhaust.

**High-Mount Starter** – This mounting configuration for inboard engine starters is to keep them out of the bilge and away from water. This requires a reverse ring-gear flywheel, and is what makes inboard engine block codes unique.

**Hot Water Heater Kit** – A kit used to provide hot water for either a hot water supply for showers or heaters on a boat.

## I

**Inline Transmission** – An engine/transmission/propshaft configuration for inboard applications where the propshaft is configured inline with the engine's crankshaft. Currently, only the Velvet Drive 71C & 72C as well as the ZF 45C transmissions are offered. These are not full power reverse transmissions.

**Integrated Transom System (ITS)** – This is a steering system that combines a 7" standoff box and external steering system into a common, integrated design that does not require boat modification. ITS is only used for performance boating.

## J

## L

**Low Water Pickup (LWP)** – An option for Bravo One XR drives. This is used for extremely high X-Dimensions (up to 22). This is commonly used on catamaran applications.

# Product Term Glossary

## M

**Manual Single Point Drain** – A single point drain system that drains the engine with the turn of a handle. Used on RWC Alpha MPI product only.

**Marinization** – The process of adding marine specific components to a long block engine.

**Mechanical Steering** – This is an economical steering system used only on the 3.0L engine.

**MerCathode** – An active cathodic corrosion protection system that feeds electrons to underwater hardware and drive units. Standard on Bravo models and available for Alpha models as a kit.

**Multi-Point Fuel Injection or Multi-Port Fuel Injection (MPI)** – This refers to a fuel system that uses a fuel injector at every intake port of the engine. Fuel is not injected into the cylinder like diesel or Optimax product, but rather onto the back of the intake valve. This allows for better intake manifold designs to promote more efficient engines and increased power.

**Multiple Helm** – The ability of a DTS installation to be rigged with up to four separate helms to control the propulsion system.

## P

**PCM09** – A digital engine control module utilizing advanced sequential fuel and spark management in addition to supporting Emission Control technology models.

**PCM555** – A digital engine control module utilizing advanced sequential fuel and spark management in addition to supporting DTS and Smart Craft.

**Plastisol® Coated Oil Pan** – A rubberized coating sprayed onto inboard engine oil pans to protect the metal oil pan from corrosive bilge water.

**Powder Paint** – Paint solids applied as a powder to an electrostatically charged surface to create a tough surface to prevent chipping.

**Power Steering** – A sterndrive steering system that uses pressure from a hydraulic pump to assist steering effort for easy, low-effort steering. This is standard with all sterndrive MerCruiser products except the 3.0L.

**Power Trim XD** – A trim control system that automatically raises and lowers the drive in the event of striking an underwater object. This is to prevent or lessen damage to the prop and drive, as well as, to return control to the operator.

## R

**Raw Water Cooling** – A cooling system that passes sea water directly through the engine block, heads and exhaust manifolds for cooling.

**Remote Oil Filter** – A feature that relocates the engine oil filter from the underside of the engine block to a higher location on top of the engine for ease of maintenance.

**Remote Oil Kit** – A kit to add remote oil if not factory installed.

**Riser Kit** – A kit to add risers if not factory installed.

## S

**Scorpion** – A Scorpion is the model name of a Tow Sports product that uses a tunnel-ram intake manifold and a specially-styled plenum for high power output.

**Seawater Pump** – A self-priming high-flow pump used to draw sea water through the drive or hull fitting and deliver cooling water to the engine. These are used on Bravo, Inboard, Tow Sports and most Alpha FWC engines.

# Product Term Glossary

**Shadow Mode** – A DTS function that allows triple or quad engine installations to be operated by a single pair of throttle and shift controls for simplified control.

**Shift Protection** – DTS protects the drive or transmission from damage. It slows the engine RPM down before going to the next selected gear position

**Small Block** – A MerCruiser V8 engine design that has 4.4 bore centers and a short deck height. Common small block engine displacements are 5.0L, 5.7L, and 6.2L.

**SmartCraft** – A standard feature on MerCruiser fuel injected engines supporting information exchange capability between the boat, engine and helm. Fuel flow, range and troll control are just some of the features that SmartCraft offers.

**Smart Start** – DTS prevents the engine starter from engaging and grinding when the engine is running. The engines start with a computer program rather than directly energizing the starter with a key. Simply tap and let go of the start button or key and a DTS engine runs through a series of algorithms to start by automatically controlling the starter and fuelling.

**S-pipe** – An exhaust system option that has S-shaped exhaust pipes included in the package. Used on Tow Sports packages to route exhaust underneath transmission mount to maximize exhaust flow and open up cockpit space in a ski boat.

**Sport Master XR Gearcase** – A special lower unit used on Bravo One XR drives that is intended for applications over 90 mph. It features a low water pick-up and a bullet-shaped nose cone to accommodate high-speed applications, and is available with an optional 2 inch shorter gearcase.

## T

**Thermostat Housing** – A component that controls engine temperature with a calibrated thermostat that controls cooling water flow through the engine.

**3-Point Drain** – A drain system that drains the raw water from an engine by the removal of three drain plugs.

**Through-Prop Exhaust** – Exhaust exiting through the transom assembly and ultimately through the propeller for quieter boat operation.

**Through-Transom Exhaust** – Exhaust exiting the transom of the boat through outlets in the boat's stern to reduce back pressure to produce more horsepower.

**Tie Bars** – Used in multiple engine installations, keeping the drives stable for higher speed applications. The tie bar connects the other drives to the starboard drive unit, so only the starboard engine requires a power steering pump.

**Transmission Guardian** – Transmission Guardian is a MerCruiser DTS feature that protects transmissions from damage. It does this by monitoring the transmission clutch pack pressure in forward and reverse gears. If the pressure drops, Transmission Guardian lowers the engine speed to prevent clutch slippage and transmission failure.

**Transom Assembly** – This is the collective assembly of the inner transom plate and the gimbal housing that sandwiches about the transom. The transom assembly mounted to the stern of a boat provides mounting, steering, tilt and trim, exhaust, coolant and corrosion protection functions. Both the engine and stern drive unit mount to the transom assembly.

**Trim Pump** – A hydraulic pump run with an electric motor used to control the trim of the drive unit. This connects directly to the battery and is installed in the engine compartment.

**Turn Key Start (TKS)** – A feature exclusive to MerCruiser carburetors equipped with an enrichment control system that only requires a turn of the key to start. TKS does not require pumping the throttle or adjusting the choke in order to start.

# Product Term Glossary

## V

**V-Drive Transmission** – An engine/transmission/propshaft configuration for inboard applications where the propshaft goes underneath the engine in a V-shape with respect to the crankshaft at between 12 to 15 degree angle. This allows the engine to be mounted toward the back of the boat for higher speed attainment.

## W

**Walter V-Drive** – A transfer case built by Walter's Machine Company that converts an inline transmission (such as the 71c or 72c) into a V-Drive configuration. This unit has a 20-degree crankshaft to propshaft angle.

**Warm Manifolds** – A cooling system design used to keep exhaust manifolds sufficiently warm to prevent water condensation in the exhaust.

**Warm Risers** – A cooling system design used to keep exhaust risers sufficiently warm to prevent water condensation in the exhaust.

**Water Distribution Housing** – A component that separates the cooling water from excess bypassed water and facilitates draining.

# ***Emissions Control Technology***

## ***Overview***

Mercury's Emissions Control Technology (**ECT**) was chartered to develop sterndrive and inboard engines that comply with the California Air Resource Board (**CARB**) & the Environmental Protection Agency (**EPA**) emission requirements.



To meet these emission standards, Mercury Marine utilizes a reliable ***catalyst system***, that is comparable to the base MerCruiser performance.

## ***Transition to Emission Control Technology***

California requires on all engines sold with a MFG date after **January 1, 2008** have to be ECT models.

For the 49 States, as of **January 1, 2011**, all engines will require Emission Control Technology.

## ***CARB Labeling***



### ***Four Stars - Super Ultra Low Emission***

The Four Star label identifies engines that meet the Air Resources Board's sterndrive and inboard marine engine 2009 exhaust emission standards.

# Emissions Control Technology

## Engine Emissions Control Features:

- ✓ Multiport Fuel Injection. *Precisely meters the fuel / air ratio.*
- ✓ Three-way catalyst *consists of a metallic honeycomb design which is coated with Platinum, Palladium, and Rhodium, known as the wash coat.*
- ✓ PCM Engine Controller (*the brain of the engine*).  
*A closed-looped control system, This computer can increase or decrease the amount of oxygen in the exhaust by adjusting the air-to-fuel ratio.*
- ✓ Pre & Post Oxygen Sensors (*located on exhaust manifolds*).  
*These sensors tells the PCM computer how much oxygen is in the exhaust.*

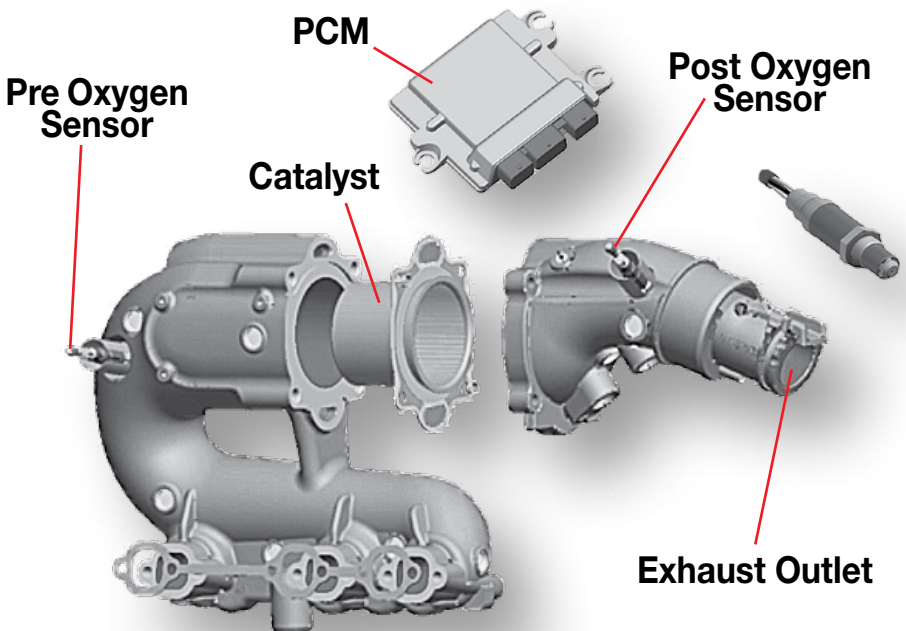

## 4.3 V6 Exhaust Manifold

# Emissions Control Technology

## MerCruiser Technical Solution

A **Catalytic Converter** is a device that uses a catalyst to reduce **HC, NO<sub>x</sub> & CO** emissions.

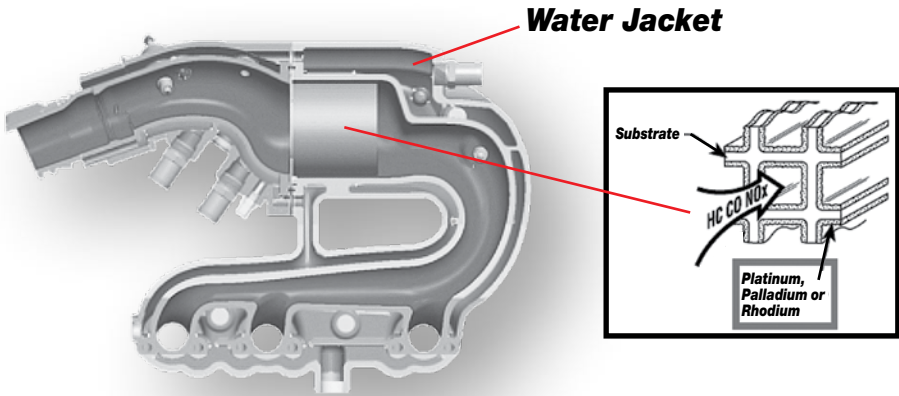

**Mercury's Catalytic Converter** has a honeycomb substrate coated with platinum, rhodium and/or palladium. This is the best design because it creates a structure that exposes the maximum surface area of catalyst to the exhaust stream, which effectively converts the harmful gas to safe gas.

**Water-Jacketed Exhaust and air gap** regulates the outer manifold surfaces from high temperatures generated by catalyst operation while maintaining the required catalyst operating temperature.

**Catalyst & Oxygen Sensors contamination** can lead to component failure!

- ✓ **Phosphorus in some oils**
- ✓ **Acetoxy Silicone**



**Use Mercury's Full synthetic catalyst "Friendly" engine oil**

# Emissions Control Technology

## MerCruiser Technical Solution

### How It Works:

1. Fuel / air mixture enter combustion chamber from **MPI**.
2. Combustion occurs and the hot exhaust gases exit the engine and head into exhaust manifold to the **catalytic converter**.
3. On the way the pre-oxygen sensor measures the amount of oxygen and sends information to **PCM**
4. Next the exhaust gases are being washed thru the honeycomb substrate coated with the **precious metals**.
5. Now the post-oxygen sensor measures exhaust and again provides feedback to **PCM**, which in return adjusts the Air/fuel mixture.

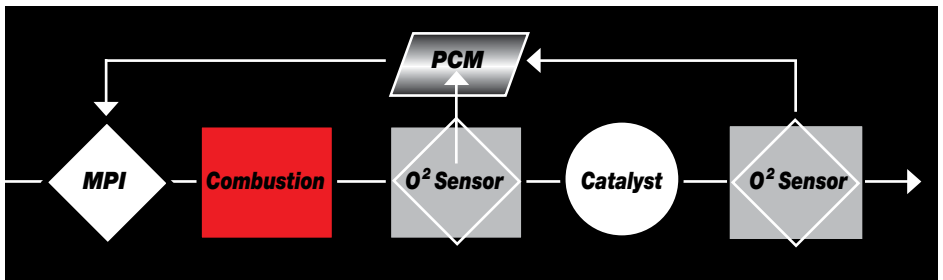

## Mercury's ECT Benefits

- ✓ Meets today's emissions standards with **90%** total reduction.
- ✓ Moving from TKS technology to **MPI**, Customers will benefit from better throttle response, improved fuel economy and an increase in power.
- ✓ **ECT** engines suffer no power loss. **Consistence performance.**

# Mercury Axis



The next generation of Axis as compared the original **Gen 1** design offers the same intuitive, easy to use piloting system to the end user.

*Axis **Gen 2** benefits the Boat Builder & Dealer.*



## **Boat Builder benefits:**

- ✓ **All New Components**
- ✓ **Simplified Installation techniques.**
- ✓ **All New Kits to better match hull requirements**
- ✓ **Quick Connect Power Steering Cylinder**
- ✓ **Axis “Kit” for Inventory flexibility to install on hulls rigged with DTS engines**

## **Dealer benefits:**

- ✓ **Simplified troubleshooting techniques and service requirements**

# Mercury Axisus

## **Axisus Changes the Experience of Docking a Boat**

Axisus allows anyone to dock a boat in a safe and relaxed way, regardless of close quarters, cross currents or side winds.

Axisus uses a **Joystick** to control steering, throttles and shifters in symphony. It gives you total control over your boat with one hand.

Intuitive & natural user interface means confidence, control & safety.

✓ **Simply move the joystick in the direction you want to go.**

✓ **The further you move it, the quicker the hull reacts in that direction.**



Axisus-equipped boats can move **forward, reverse, laterally, at an angle, or rotate in their own length** without the need for bow thrusters.

Multiple inputs (movement and twisting of joystick) result in boat moving laterally and rotating simultaneously.

**Provides the ability to “steer” while moving sideways.**

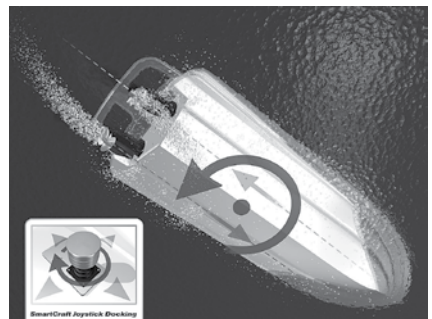
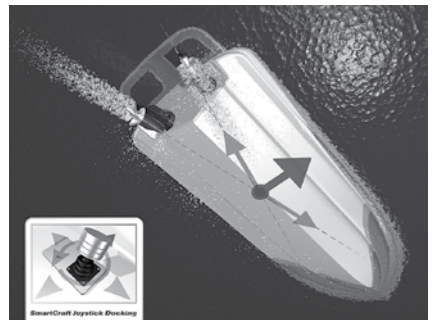

# Mercury Axis

## Axis Architecture

Axis utilizes **TWO** independently steered, (no tie bars), DTS throttled and shifted **Bravo Three** stern drives, controlled by a joystick through a network of on-board computers.

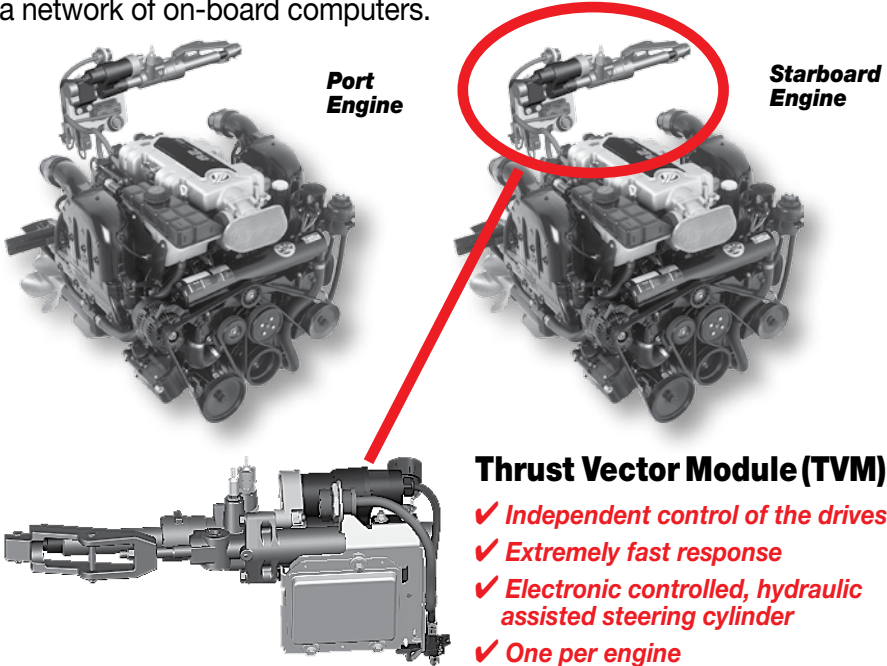

### Thrust Vector Module (TVM)

- ✓ Independent control of the drives
- ✓ Extremely fast response
- ✓ Electronic controlled, hydraulic assisted steering cylinder
- ✓ One per engine

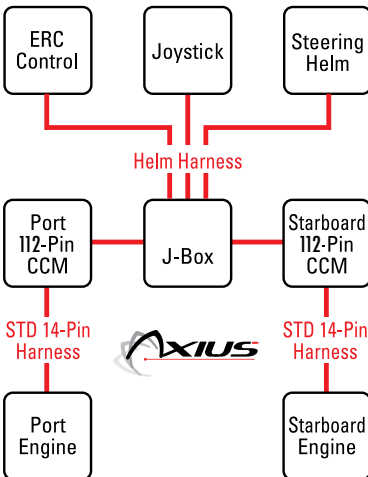

**The Axis System is built on Mercury's proven SmartCraft Integrated Technology.**

- ✓ **DTS Digital Throttle & Shift** technology
- ✓ **Mercury's Power Steering System** (Electronic to Hydraulic)
- ✓ **Precision Rigging Harnesses, J-Box, & waterproof connectors**
- ✓ **Throttle, Shifting & Power Steering** are "drive-by-wire"

# Mercury Axis

The Axis system is perfect for dual sterndrive boat packages between 25 and 40 feet, using engines ranging from **twin 5.0 MPI** to **twin 8.2 MAG HO**. *The Axis system provides boaters with an incredible level of intuitive, precise control.*

## Axis vs. Axis PREMIER

**Axis** offers comfortable precise maneuverability and handling to match your customer's boating style.

The **Axis PREMIER** version is for serious boaters that includes Axis features plus more sophisticated navigation devices.

Feature	Axis	Axis Premier
<b>1. Joystick Control System</b> Docking Mode	✓	✓
<b>2. DTS Throttle &amp; Shift</b>	✓	✓
<b>3. Next Generation Power Steering</b> Electronic to Hydraulic	✓	✓
<b>4. VesselView</b>		✓
<b>5. Axis Control Pad</b> Auto Heading Waypoint Sequencing Skyhook® Anchoring		✓

## Axis Features

### 1. Begins with the Joystick Control System

Joystick control allows Axis-powered boats to move sideways, at an angle, or even in a circle, because the drive systems steer, shift and throttle independently. *The joystick provides ultimate control for precision maneuverability and ease in boating.*

### Docking Mode

When closing in on a dock or pier, use a more gentle movement of the stick, since the maximum RPM is reduced to 50% for less sensitivity. *Eliminates abrupt boat movements in tight quarters for near perfect docking.*

# Mercury Axis



## 2. SmartCraft Digital Throttle & Shift

SmartCraft Integrated Marine Technology maximizes performance and delivers a greater sense of security.

*Digital Throttle & Shift utilizes drive-by-wire technology for instant throttle response, amazingly smooth effortless control with no maintenance or durability worries.*

- ✓ Smooth Shifting & Throttle Operation
- ✓ Single Lever Operation
- ✓ Throttle Only
- ✓ Docking Mode
- ✓ Automatic Engine Synchronization
- ✓ Troll Control
- ✓ Helm Transfer
- ✓ Maintenance-Free on Throttle/Shift Cables
- ✓ Smart Start/Stop

### DTS Functionality

- ✓ **1 Lever** Allows the throttle & shift function of all engines to be controlled by the port side control handle.
- ✓ **Throttle Only** Engine warm up.
- ✓ **Troll Control** Set/Adjust trolling speed.
- ✓ **Docking Mode** Reduces maximum engine power in joystick mode by **50%** of normal for less sensitivity.
- ✓ **Sync On/Off** Engines RPM are automatically synchronized when the levers are within 10% of each other.
- ✓ **Helm Transfer** Transfers control between different helm stations.



## 3. Next Generation Power Steering

(Electronic to Hydraulic)

Mercury Power Steering system delivers *automotive like ease of steering, precise responsive boat control and handling with no undesirable steering torque.*



## Axius Premier Features

**Axius PREMIER** adds a number of *innovative navigational features & systems* to the **Axius** joystick & steering control.

## 4. SmartCraft VesselView®

VesselView® provides access to and monitors all of the vessel's systems and navigational display from one location.

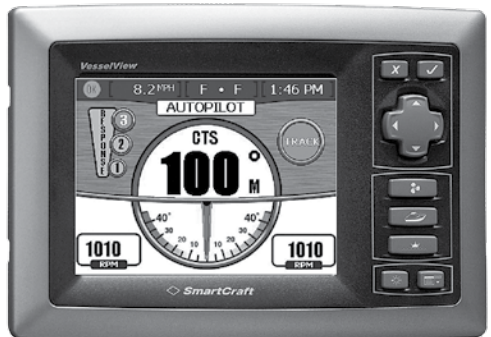

### Key Attributes

- ✓ Easy to View **5"** color TFT screen
- ✓ One-touch operation to access:

**Propulsion screens:** *Engine operation & vitals.*

**Vessel screens:** *Trip log, depth display, tank status.*

**Environmental and navigation screens:** *Latitude and longitude repeater from GPS and fuel computer.*

# Mercury Axis

## 5. Axis Control Pad

With a touch of a finger the Axis CAN Control pad can make course corrections.

*Simple & Convenient.*



### Key Functions:

## Auto Heading

Using a precise **built-in compass**, Auto Heading allows the captain to maintain course, speed and make precise corrections easily and with the touch of a finger. When Auto Heading is enabled ...

- ✓ The captain can vary the course port or starboard by using the arrow keys on control pad. The course will change by **10°** per tap.
- ✓ **OR**, by simply holding the joystick over port or starboard, until a beep is heard the captain can correct course, in **1 degree increments for every beep**.

## Waypoint Sequencing / Tracking

Working with an on-board chart plotter, this feature allows boaters to pilot a route (*with multiple points in between*) to their final destination.

*Once programmed, this system precisely navigates to the set point(s).*

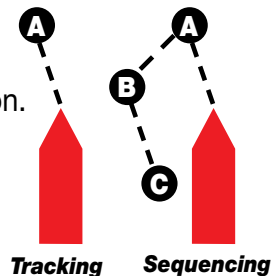

## Skyhook® Station Keeping

When engaged, this system utilizes global positioning system technology (GPS) and an electronic compass to automatically control shifting, throttling, and steering to maintain heading and approximate position.

*Especially useful when holding a position waiting for a fuel dock slip, a bridge to open or when prepping the boat for docking.*

## Axius Premier Control Pad Functionality

### Turn

Each time the button is pressed the boat will change its direction by **10°** to PORT or bump joystick to change course in **1°** increments.

### Resume

If Auto-heading was disabled, by steering wheel this button will put the ship back on its previous course.

### Auto-heading

The boat keeps the current course using the integrated heading sensor.

### Skyhook® Station Keeping

Maintains boat heading and approximate position.

### Turn

Each time the button is pressed the boat will change its direction by **10°** to PORT or bump joystick to change course in **1°** increments.

### Waypoint Sequence

The ship will follow multiple waypoints (routes) on the chart plotter.

### Track waypoint

The ship will follow a single waypoint shown on the chart plotter.



## GPS Satellite Antenna & IMU Compass

GPS Satellite Antenna and IMU Compass work together to accurately support a variety of features including: **Waypoint Tracking & Sequencing, Auto Heading & Skyhook Station Keeping.**

\* Skyhook® availability at boat manufacturers discretion

**MerCruiser's SeaCore** technology is a comprehensive corrosion protection system that improves upon MerCruiser's outstanding standard built-in corrosion features. *All which makes for the ultimate in corrosion protection.*

## **Standard Built-in Corrosion Features**

### ✓ **Exclusive XK360 Low Copper Alloy**

Copper is like a corrosion magnet. This high strength aluminum alloy has *less than 0.2% copper content* and is extremely corrosion resistant

### ✓ **MercFusion Paint System**

Irridite, **EDP** (Electro-Deposition Primer) and statically applied phantom black Powder Paint creates a tough, durable corrosion-resistant barrier.

### ✓ **Multiple Ultra-Pure Aluminum Sacrificial Anodes**

Provides enhanced protection *versus* traditional zincs anodes.

### ✓ **EDP coated Manifolds & Dry Joint Exhaust Elbows**

Adds to the corrosion endurance of these components.

### ✓ **Stainless Steel Trim hoses With Braided Bonding Straps**

Completes continuity circuit on the transom assembly and stern drive unit components, to ensure a good ground and bonding of all isolated components for enhanced corrosion endurance.

### ✓ **Flo-Torq Propeller hubs**

Continuity devices are *built-in* to prevent corrosion damage to the stainless steel propellers. On solid hub propellers the propshaft and hardware needs to be greased periodically.

**Three Year Limited  
Corrosion Failure Warranty**  
*MerCruiser stands behind every model.*



**MerCruiser sterndrives** with their standard built-in corrosion features are legendary for their unequalled strength and durability.

Now add the **SeaCore Corrosion Protection System**, and MerCruiser broadens the life of engine and drive components for superior corrosion defiance. SeaCore is available on all **Bravo One, Bravo Two and Bravo Three** drive applications.

## Standard SeaCore Corrosion Features

- ✓ Industrial Hard Anodizing & Proprietary Sealing Treatment on Drives.
- ✓ Stainless Steel Package on Engine & Drive.
- ✓ Closed Cooling System.
- ✓ Engine mounted integrated freshwater flush attachment.
- ✓ MerCathode corrosion prevention.
- ✓ Four Year Limited Corrosion Failure Warranty.

## SeaCore Hardcoat Anodizing

As Sales associates, it's hard to sell something you can't see. The anodizing feature is **under the black paint** in the chemical make-up of the metal.

**SeaCore Hardcoat Anodizing** is a heavy-duty anodizing and proprietary sealing treatment to all underwater aluminum parts. This process actually deeply penetrates the aluminum and changes the molecular structure of the **XK-360 aluminum alloy**, creating a shield against the negative effects of galvanic corrosion.

**The final result is a surface that's more abrasion-resistant than case-hardened steel and non-conductive to reduce electrolysis.**

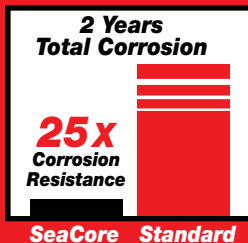

The chart illustrates a direct comparison between **standard** paint process and **SeaCore's hard coat anodizing**.

The product lifecycle test period was measured every week for **2 years** in a normal saltwater environment. SeaCore units had very little corrosion.

**For serious Saltwater corrosion protection, the SeaCore system is well worth the extra cost!**

## Stainless Steel Package

MerCruiser's SeaCore system provides additional corrosion protection with the use of quality grade 316 stainless steel components on both the engine and the drive assemblies.

### Key Components

- ✓ All underwater fasteners on the drive.
- ✓ Bravo Three bearing carrier.
- ✓ Steering shaft, motor mounts & more.

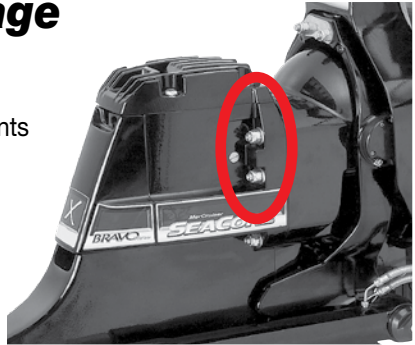

## Closed Cooling System

MerCruiser's Closed Cooling system with **5-Year** long life coolant seals the engine from saltwater. Raw seawater is used to cool the heat exchanger.

The Air-actuated drain is a system that can easily drain critical components to prevent freezing and allow for extended late seasonal boating.

**Long-term Durability.**

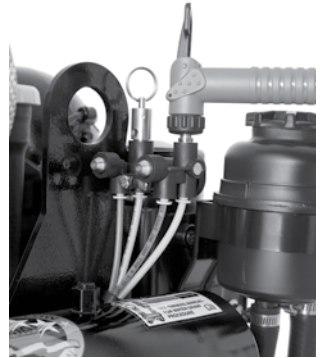

## Freshwater Flush Port

Whether on a trailer or a boat lift is easy to flush the saltwater out of the engine cooling system along with the drive unit. Located in the boat, on the engine block is a convenient garden hose adapter to effectively flush the unit.

**Periodical flushing prolongs the life of the product against corrosion.**

## MerCathode

An active corrosion prevention system monitors the galvanic potential of the drive and condition of the anodes. It uses **micro-voltage** to electrically offset corrosion, providing continuous cathodic protection.

**Provides corrosion prevention and durability.**



### XK360

✓ Low copper, high strength aluminum alloy.  
**Corrosion resistance.**

**Ultra-Pure Aluminum Anodes or Magnesium Anode Kit**

### MercFusion Paint System

✓ (Irridite, EDP & Powder Paint)  
**Creates a tough, durable corrosion resistant barrier.**

### MerCathode®

✓ Active corrosion prevention.

### SeaCore Hard Anodizing & Sealing Treatment

✓ **More abrasion-resistant to reduce galvanic corrosion.**  
✓ **Non-conductive to reduce electrolysis.**

### Integrated Freshwater Flush

✓ **Preventive corrosion protection.**

**2 Anti-cavitation Plate anodes**

**Propshaft Anode**

### Closed Cooling System

✓ Seals out saltwater from block.

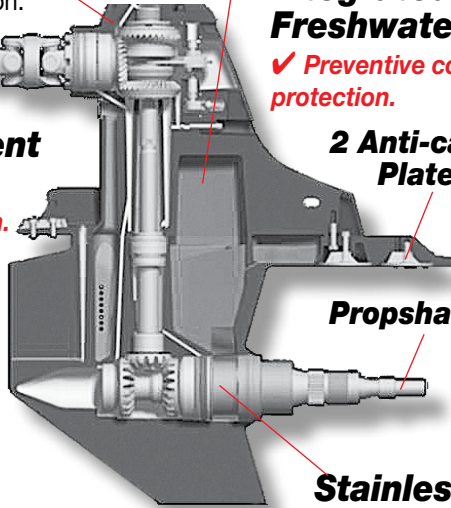

**Stainless Steel Bearing Carrier**

✓ (Bravo Three)  
**Strength & Durability.**



**Four Year Limited Corrosion Failure Warranty**

## MerCruiser's SeaCore compared to Volvo's OceanX™

Volvo's Ocean X™ drive is produced with a system that involves the EC<sup>2</sup> pre-treatment process. Mercury is very familiar with this process and has been testing it in both the lab and the field.

The Volvo's Ocean X Titanium-ceramic coating is an electrically deposited conversion coating process that results in a "softer coating" on the aluminum.

Additional features: Freshwater Cooling Active Corrosion Protection

Mercury's SeaCore uses a hard anodizing process that grows a hard, abrasion resistant, aluminum oxide coating from the aluminum itself (Instead of simply depositing a coating on the surface).

Additional features: Closed Cooling MerCathode

Additional Stainless Steel hardware Engine Mounted Freshwater port



# ENGINES

## STERNDRIVE

**3.0 MPI ECT** —

**4.3 MPI ECT** —

**5.0 MPI ECT** —

**350 MAG ECT** —

**377 MAG ECT** —

**8.2 MAG ECT** —

**8.2 MAG HO ECT** —

# 3.0 MPI ECT

# Sterndrive

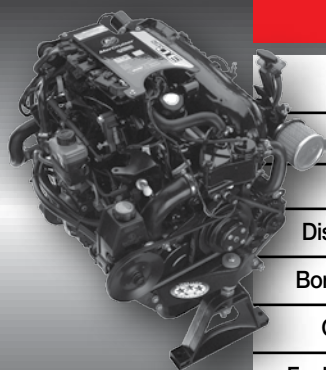

SmartCraft Integrated Marine Technology maximizes performance and delivers a greater sense of security with innovative features.



4-Star C.A.R.B. rating on 87 octane fuel for super ultra low emissions.

## SPECIFICATIONS

HP/kW	135 / 99.3
Max RPM (WOT)	4400 - 4800
Cylinders	4 (In-Line)
Displacement (CID/L)	181 / 3.0
Bore X Stroke (in/mm)	4.00 x 3.60 / 101 x 91
Compression Ratio	9.3:1
Fuel/Ethanol Tolerance	87 Octane / up to 10% Ethanol
Fuel Delivery System	Multi-Point Electronic Fuel Injection (MPI)
Fuel Induction System	Single Piece Iron Intake w/ 56mm throttle body
Engine Control System	PCM 09 w/SmartCraft CAN Capability, OBD-M Diagnostics, O2 Sensors
Ignition System	Crank Fired High Voltage w/ Knock Control
Charging (Amp/Watt)	65 / 917 Alternator
Water Drain System	Quick-Disconnect Drain Hoses with Flush Feature
Exhaust System	EDP Coated Iron Manifold w/dry-joint elbow
Cooling System	Thermostatically Controlled, raw water
Accessory Drive System	V- Belt
Recommended Oil	Mercury MerCruiser Full Synthetic 20W-40W, NMMA FCW Rated
Engine Guardian System	Overheating, Low Voltage, Over-Rev & Low Drive Lube
Dimensions (LxWxH) in	29 x 26 x 21
Dimensions (LxWxH) mm	730 x 660 x 533
Weight w/Alpha (lbs/kg)	689 / 313
Optional Freshwater Cooling	Available
Digital Throttle & Shift	N/A

## KEY ATTRIBUTES

### ✓ **Sequential Multi-Port Fuel Injection**

Precisely outlines the exact amount of fuel for all driving conditions.

#### **Benefits:**

- *Easy starts, regardless of temp.*
- *Better throttle response.*
- *Smooth, stable idling.*
- *Increased fuel efficiency.*
- *Reduced cost of operation.*

### ✓ **Cool Fuel Module**

Water cooled fuel delivery system provides hi-PSI fuel to the injectors.

- Cools fuel to prevent vapor lock
- Spin-on type water separating fuel filter helps protect the engine and fuel system

*Reliability with Ease of Maintenance.*

### ✓ **High Output Alternator**

**65 Amps @ Maximum RPM**   **38 Amps @ idle.**

Provides battery charging on demand allowing use of electronics, alarms & other accessories. *Dependability.*



### ✓ **Drive Lube Monitor**

Easy-to-see translucent bottle for checking level of gearcase lubricant with audible level warning.

*Provides drive protection and simple maintenance.*

### ✓ **Exclusive Engine Guardian**

Senses potential problems and virtually eliminates the chance for engine or drive damage due to overheating, low oil pressure or low drive lubricant. *Protects your Investment.*

## KEY ATTRIBUTES

### ✓ **Dry-Joint Exhaust Design**

Separates cooling water & exhaust at junctions to prevent water leaks from reaching critical engine components.

*Long-Term Endurance with built-in Reliability*

### ✓ **Color-Coded Service Points**

Allows easy checking of fluids levels and convenient filling of reservoirs.

*Ease of Ownership.*

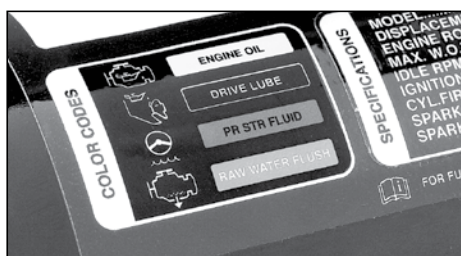

### ✓ **Easy-Maintenance Features**

#### **Front Mount Oil Dipstick**

- Easy remove / replace design
- Fitting allows oil to be pumped out

#### **Front Mount Oil Fill**

#### **Easy Access Spin-On Type Oil Filter**

*Convenient to use and Easy to service.*

### ✓ **Convenient Water Drain & Flush system**

Simplifies periodic maintenance and allows boaters to extend their boating season into the cooler months.

*Ease of Ownership.*



## ADDITIONAL FEATURES / BENEFITS

<b>MerCruiser's ECT Technology</b>	Multiport Fuel Injection (MPI) PCM09 Control module Catalyst System (Exhaust Manifolds) Dual Oxygen sensors This system provides excellent performance while producing Super Ultra-Low emissions levels.
<b>In-Line 4-Cylinder</b>	GM cast iron base engine with single-piece intake/exhaust manifold for long life and proven durability .
<b>High Voltage Ignition</b>	High energy ignition with knock control provides instant starts and more power for performance.
<b>SmartCraft</b>	Delivers information regarding key engine functions from fuel usage, RPM & engine guardian to slow trolling RPM control
<b>EDP (Electro- Deposition Paint) Coating</b>	Featured on the Exhaust manifolds, risers, elbows & Thermostat housings add to corrosion endurance of these components
<b>Power Steering</b>	Reduces steering effort and provides enhanced hull control at all boat speeds

## AVAILABLE DRIVES

**Alpha, Bravo One, Bravo Two, Bravo Three**

Visit [mercurymarine.com](http://mercurymarine.com) for details  
on the best performing drives in the world.

# 4.3 MPI ECT

# Sterndrive

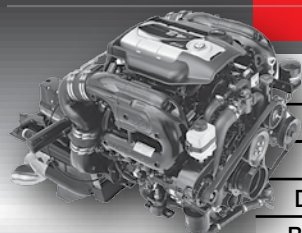

## SPECIFICATIONS

HP/kW	220 / 162
Max RPM (WOT)	4400 - 4800
Cylinders	V 6
Displacement (CID/L)	262 / 4.3
Bore X Stroke (in/mm)	4.00 x 3.48 x / 101 x 88
Compression Ratio	9.4:1
Fuel/Ethanol Tolerance	87 Octane / up to 10% Ethanol
Fuel Delivery System	Multi-point Electronic Fuel Injection (EFI)
Engine Control System	PCM 09 w/SmartCraft CAN Capability OBD-M Diagnostics & O2 Sensors
Induction System	2 Piece Long Runner Intake w/75mm throttle body
Ignition System	Crank Fired High Voltage Switch w / Knock Control
Charging (Amp/Watt)	65 / 917 Alternator
Water Drain System	Single Point Manual (Alpha) Three Point Manual (Bravo) Air Actuated Single-Point (FMC or SeaCore)
Exhaust System	Iron Manifolds w/ EDP Coated Dry Joint Exhaust Elbow
Cooling System	Thermostatically Controlled, Raw Water
Accessory Drive System	Serpentine Belt
Recommended Oil	Mercury MerCruiser Full Synthetic 20W-40W, NMMA FCW Rated
Engine Guardian System	Low oil pressure, high coolant temperature, low sea water pressure, low voltage, over- rev control and low drive lube
Dimensions (LxWxH) in	28 x 30 x 22
Dimensions (LxWxH) mm	696 x 740 x 559
Weight w/Alpha (lbs/kg)	949 / 430
Weight w/Bravo One (lbs/kg)	1007 / 457
Weight w/Bravo Two (lbs/kg)	1022 / 464
Weight w/Bravo Three (lbs/kg)	1032 / 468
Freshwater Cooling	Optional or Standard on SeaCore
Digital Throttle & Shift	NA



SmartCraft Integrated Marine Technology maximizes performance and delivers a greater sense of security with innovative features.



For full details on this complete corrosion protection system see page 24-27.



4-Star C.A.R.B. rating on 87 octane fuel for super ultra low emissions.

# Sterndrive 4.3 MPI ECT

## KEY ATTRIBUTES

### ✓ **Sequential Multi-Port Fuel Injection**

Precisely outlines the exact amount of fuel for all driving conditions.

#### **Benefits:**

- *Better throttle response.*
- *Easy starts, regardless of temp.*
- *Increased fuel efficiency.*
- *Smooth, stable idling.*
- *Reduced cost of operation.*

### ✓ **Cool Fuel Module**

Water cooled fuel delivery system provides Hi-psi fuel to the injectors.

- Cools fuel to prevent vapor lock
- Spin-on type water separating fuel filter helps protect the engine and fuel system

*Reliability with Ease of Maintenance.*

### ✓ **High Output Alternator**

**65 Amps @ Maximum RPM**   **38 Amps @ idle.**

Provides battery charging on demand allowing use of electronics, alarms & other accessories. *Dependability.*



### ✓ **Drive Lube Monitor**

Easy-to-see translucent bottle for checking level of gearcase lubricant with audible level warning.

*Provides drive protection and simple maintenance.*

### ✓ **Exclusive Engine Guardian**

Senses potential problems and virtually eliminates the chance for engine or drive damage due to overheating, low oil pressure or low drive lubricant. *Protects your Investment.*

# 4.3 MPI ECT Sterndrive

## KEY ATTRIBUTES

### ✓ **Dry-Joint Exhaust Design**

Separates cooling water & exhaust at junctions to prevent water leaks from reaching critical engine components.

*Long-Term Endurance with built-in Reliability*

### ✓ **Color-Coded Service Points**

Allows easy checking of fluids levels and convenient filling of reservoirs.

*Ease of Ownership.*

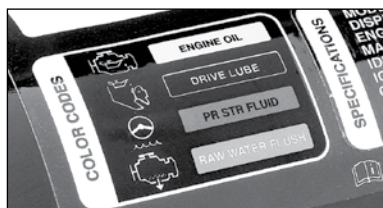

### ✓ **Easy-Maintenance Features**

#### **Top Mount Oil Dipstick**

- Easy to remove & replace
- Fitting allows oil to be pumped out

#### **Top/Front Mounted Oil Filter**

- Easy access for removal
- Spin-on automotive type



### ✓ **Front Mount Oil Fill**

- Easy access
- Easy to pour spout

*Convenient to use and Easy to service*



### ✓ **MerCathode Corrosion Protection**

Standard on Bravo models, available on Alpha models. This active cathodic corrosion protection system feeds electrons to underwater hardware and drive units. *Enhanced corrosion protection.*

# Sterndrive

# 4.3 MPI ECT

## ADDITIONAL FEATURES / BENEFITS

### **MerCruiser's ECT Technology**

Multiport Fuel Injection (MPI)  
PCM09 Control Module  
Catalyst System (Exhaust Manifolds)

#### **Dual Oxygen Sensors on each manifold**

This system provides excellent performance while producing Super Ultra-Low emission levels

### **Proven V6**

GM cast iron base engine with Dual Plane intake manifold for more power and durability.

### **High Voltage Ignition**

High energy ignition with knock control provides instant starts and more power for performance.

### **EDP (Electro-Deposition Paint) Coating**

Featured on the Exhaust manifolds, risers, elbows & Thermostat housings add to corrosion endurance of these components.

### **Power Steering**

Reduces steering effort and provides enhanced hull control at all boat speeds.

### **Easy Ownership**

Operates on easy to find, less expensive 87 octane fuel.

Serpentine belt system for longer belt life.

**3 year/300 hour** maintenance interval on many periodic service items saves time, money and keeps you on the water.

## AVAILABLE DRIVES

**Alpha, Bravo One, Bravo Two, Bravo Three**

Visit [mercurymarine.com](http://mercurymarine.com) for details on the best performing drives in the world.

# 5.0 MPI ECT

# Sterndrive

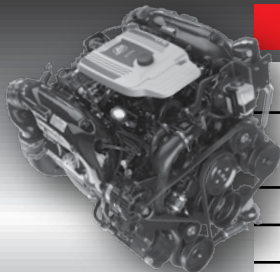

For full details on this complete corrosion protection system see page 24-27.



SmartCraft Integrated Marine Technology maximizes performance and delivers a greater sense of security with innovative features.



Digital Throttle & Shift utilizes cable-less operation which eliminates helm maintenance and gives instant throttle response.



4-Star C.A.R.B. rating on 87 octane fuel for super ultra low emissions.

## SPECIFICATIONS

HP/kW	260 / 191
Max RPM (WOT)	4600 - 5000
Cylinders	V 8
Displacement (CID/L)	305 / 5.0
Bore X Stroke (in/mm)	3.73 x 3.48 / 95 x 88
Compression Ratio	9.4:1
Fuel/Ethanol Tolerance	87 Octane / up to 10% Ethanol
Engine Control System	PCM 09 w/SmartCraft CAN Capability OBD-M Diagnostics & O2 Sensors
Fuel Delivery System	GenII Cool Fuel-Alpha / GenIII Cool Fuel-Bravo
Fuel Injection System	Multi-point Electronic Fuel Injection (MPI)
Induction System	2 Piece Long Runner Intake w/75mm throttle body (80mm w/DTS)
Ignition System	Crank Fired High Voltage Switch w/Knock Control
Charging (Amp/Watt)	65 / 917 Alternator
Water Drain System	Single Point Manual (Alpha) Three Point Manual (Bravo) Air Actuated Single-Point (FMC or SeaCore)
Exhaust System	EDP Coated Iron Manifold w/ Dry Joint Elbow
Cooling System	Thermostatically Controlled, Raw Water
Accessory Drive System	Serpentine Belt
Recommended Oil	Mercury MerCruiser Full Synthetic 20W-40W, NMMA FCW Rated
Engine Guardian System	Low oil pressure, high coolant temperature, low seawater pressure, low voltage, over-rev control, knock control
Dimensions (LxWxH) in	32 x 30 x 22
Dimensions (LxWxH) mm	814 x 740 x 559
Weight w/Alpha (lbs/kg)	1059 / 480
Weight w/Bravo One (lbs/kg)	1117 / 507
Weight w/Bravo Two (lbs/kg)	1132 / 513
Weight w/Bravo Three (lbs/kg)	1019 / 518
Freshwater Cooling	Optional or Standard on SeaCore
Digital Throttle & Shift	Optional

## KEY ATTRIBUTES

### ✓ **Sequential Multi-Port Fuel Injection**

Precisely outlines the exact amount of fuel for all driving conditions.

#### **Benefits:**

- *Easy starts, regardless of temp.*
- *Smooth, stable idling.*
- *Better throttle response.*
- *Increased fuel efficiency.*
- *Reduced cost of operation.*

### ✓ **Exclusive GEN III Cool Fuel Module (Bravo)**

Water cooled fuel delivery system provides hi-PSI fuel to the injectors.

- *Cools fuel to prevent vapor lock*
- *Contains water/fuel separating filter*

*Reliability with Ease of Maintenance.*



### ✓ **High Output Alternator**

**65 Amps @ Maximum RPM**   **38 Amps @ idle.**

Provides battery charging on demand allowing use of electronics, alarms & other accessories. *Dependability.*



### ✓ **Drive Lube Monitor**

Easy-to-see translucent bottle for checking level of gearcase lubricant with audible level warning. *Provides drive protection and simple maintenance.*

### ✓ **Exclusive Engine Guardian**

Senses potential problems, alerts operator and even reduces engine power when needed. *Peace of Mind; protects your investment.*

#### **Vital functions monitored:**

- *Low Oil Pressure*
- *Engine Temperature*
- *Low Drive Lube*
- *Low Seawater Pressure*
- *Low Voltage*
- *Over-Rev Control*
- *Knock Control*

## KEY ATTRIBUTES

### ✓ **Dry-Joint Exhaust Design**

Separates cooling water & exhaust at junctions to prevent water leaks from reaching critical engine components.

*Long-Term Endurance with built-in Reliability*

### ✓ **Color-Coded Service Points**

Allows easy checking of fluids levels and convenient filling of reservoirs.

*Ease of Ownership.*

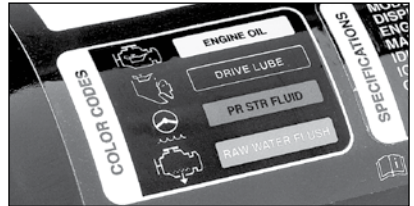

### ✓ **Simple-Maintenance Features**

**Easy Access Oil Dipstick** (Fitting allows oil to be pumped out)

**Top Mount Oil Fill & Top / Front Mounted Oil Filter**

*Convenient to use and Easy to service.*

### ✓ **Convenient Water Drain Systems**

Simplifies periodic maintenance and allows boaters to extend their boating season into the cooler months.

Single-Point Drain on Alpha drive models



Three-Point Manual Drain on Bravo drive models

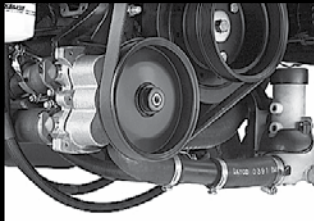

Air Actuated Single-Point Drain on FWC or SeaCore models



*Refer to Page 62 for more information*

### ✓ **High-Displacement Brass Seawater Pump**

Increases cooling system capacity, more resistant to wear.

*Improved durability.*

## ADDITIONAL FEATURES / BENEFITS

<b>MerCruiser's ECT Technology</b>	Multiport Fuel Injection (MPI) PCM09 Control Module Catalyst System (Exhaust Manifolds) <b>Dual Oxygen Sensors on each manifold</b> This system provides excellent performance while producing Super Ultra-Low emission levels
<b>Proven V8 Durability</b>	GM cast iron base engine with long intake runner manifold for better acceleration and handling heavy loads.
<b>High Voltage Ignition</b>	High energy ignition with knock control provides instant starts and more power for performance.
<b>SmartCraft</b>	Delivers information regarding key engine functions from fuel usage, RPM & engine guardian to slow trolling RPM control
<b>EDP (Electro-Deposition Paint) Coating</b>	Featured on the Exhaust manifolds, risers, elbows & Thermostat housings add to corrosion endurance of these components
<b>Power Steering</b>	Reduces steering effort and provides enhanced hull control at all boat speeds
<b>MerCathode Corrosion Protection</b>	Standard on Bravo models, available on Alpha models. This active cathodic corrosion protection system feeds electrons to underwater hardware and drive units.

## AVAILABLE DRIVES

**Alpha, Bravo One, Bravo Two, Bravo Three**

Visit [mercurymarine.com](http://mercurymarine.com) for details on the best performing drives in the world.

# 350 MAG ECT

# Sterndrive

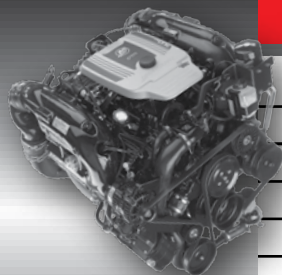

For full details on this complete corrosion protection system see page 24-27.



SmartCraft Integrated Marine Technology maximizes performance and delivers a greater sense of security with innovative features.



Digital Throttle & Shift utilizes cable-less operation which eliminates helm maintenance and gives instant throttle response.

## SPECIFICATIONS

HP/kW	300 / 221
Max RPM (WOT)	4800 - 5200
Cylinders	V 8
Displacement (CID/L)	350 / 5.7
Bore X Stroke (in/mm)	4.00 x 3.48 / 101 x 88
Compression Ratio	9.4:1
Fuel/Ethanol Tolerance	87 Octane / up to 10% Ethanol
Engine Control System	PCM 09 w/SmartCraft CAN Capability OBD-M Diagnostics & O2 Sensors
Fuel Delivery System	Gen II Cool Fuel - Alpha Gen III Cool Fuel - Bravo
Fuel Injection System	Multi-point Electronic Fuel Injection (MPI)
Induction System	2 Piece Long Runner Intake w/75mm throttle body (80mm w/DTS)
Ignition System	Crank Fired High Voltage Switch w/Knock Control
Charging (Amp/Watt)	65 / 917 Alternator
Water Drain System	Single Point Manual (Alpha) Three Point Manual (Bravo) Air Actuated Single-Point (FMC or SeaCore)
Exhaust System	EDP Coated Iron Manifold w/ Dry Joint Elbow
Cooling System	Thermostatically Controlled, Raw Water
Accessory Drive System	Serpentine Belt
Recommended Oil	Mercury MerCruiser Full Synthetic 20W-40W, NMMA FCW Rated
Engine Guardian System	Low oil pressure, high coolant temperature, low seawater pressure, low voltage, over-rev control, knock control
Dimensions (LxWxH) in	32 x 30 x 22
Dimensions (LxWxH) mm	814 x 740 x 559
Weight w/Alpha (lbs/kg)	1059 / 480
Weight w/Bravo One (lbs/kg)	1117 / 507
Weight w/Bravo Two (lbs/kg)	1132 / 513
Weight w/Bravo Three (lbs/kg)	1142 / 518
Freshwater Cooling	Standard on SeaCore Model
Digital Throttle & Shift	Optional

## KEY ATTRIBUTES

### ✓ **Sequential Multi-Port Fuel Injection**

Precisely outlines the exact amount of fuel for all driving conditions.

#### **Benefits:**

- *E.Z. starts, regardless of temp.*
- *Better throttle response.*
- *Smooth, stable idling.*
- *Increased fuel efficiency.*
- *Reduced cost of operation.*

### ✓ **Exclusive GEN III Cool Fuel Module (Bravo)**

Water cooled fuel delivery system provides hi-PSI fuel to the injectors.

- Cools fuel to prevent vapor lock
- Contains water/fuel separating filter

*Reliability with Ease of Maintenance.*



### ✓ **High Output Alternator**

**65 Amps @ Maximum RPM**   **38 Amps @ idle.**

Provides battery charging on demand allowing use of electronics, alarms & other accessories. *Dependability.*



### ✓ **Drive Lube Monitor**

Easy-to-see translucent bottle for checking level of gearcase lubricant with audible level warning. *Provides drive protection and simple maintenance.*

### ✓ **Exclusive Engine Guardian**

Senses potential problems, alerts operator and even reduces engine power when needed. *Peace of Mind; protects your investment.*

#### **Vital functions monitored:**

- Low Oil Pressure
- Low Voltage
- Engine Temperature
- Over-Rev Control
- Low Drive Lube
- Knock Control

## KEY ATTRIBUTES

### ✓ **Dry-Joint Exhaust Design**

Separates cooling water & exhaust at junctions to prevent water leaks from reaching critical engine components.

*Long-Term Endurance with built-in Reliability*

### ✓ **Color-Coded Service Points**

Allows easy checking of fluids levels and convenient filling of reservoirs.

*Ease of Ownership.*

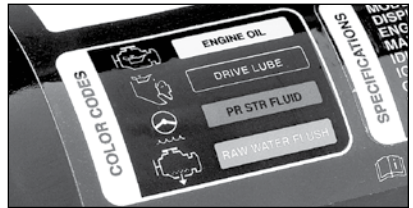

### ✓ **Simple-Maintenance Features**

**Easy Access Oil Dipstick** (Fitting allows oil to be pumped out)

**Top Mount Oil Fill & Top / Front Mounted Oil Filter**

*Convenient to use and Easy to service.*

### ✓ **Convenient Water Drain Systems**

Simplifies periodic maintenance and allows boaters to extend their boating season into the cooler months.

Single-Point Drain on Alpha drive models



Three-Point Manual Drain on Bravo drive models

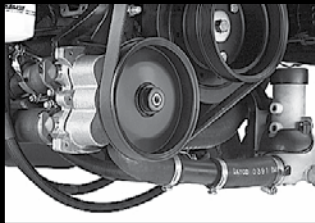

Air Actuated Single-Point Drain on FWC or SeaCore models



**Refer to Page 62 for more information**

### ✓ **High-Displacement Brass Seawater Pump**

Increases cooling system capacity, more resistant to wear.

*Improved durability.*

## ADDITIONAL FEATURES / BENEFITS

<b>MerCruiser's ECT Technology</b>	Multiport Fuel Injection (MPI) PCM09 Control Module Catalyst System (Exhaust Manifolds) <b>Dual Oxygen Sensors on each manifold</b> This system provides excellent performance while producing Super Ultra-Low emission levels
<b>Proven V8 Durability</b>	GM cast iron base engine with long intake runner manifold for better acceleration and handling heavy loads.
<b>High Voltage Ignition</b>	High energy ignition with knock control provides instant starts and more power for performance.
<b>SmartCraft</b>	Delivers information regarding key engine functions from fuel usage, RPM & engine guardian to slow trolling RPM control
<b>EDP (Electro-Deposition Paint) Coating</b>	Featured on the Exhaust manifolds, risers, elbows & Thermostat housings add to corrosion endurance of these components
<b>Power Steering</b>	Reduces steering effort and provides enhanced hull control at all boat speeds
<b>MerCathode Corrosion Protection</b>	Standard on Bravo models, available on Alpha models. This active cathodic corrosion protection system feeds electrons to underwater hardware and drive units.

## AVAILABLE DRIVES

**Alpha, Bravo One, Bravo Two, Bravo Three**

Visit [mercurymarine.com](http://mercurymarine.com) for details on the best performing drives in the world.

# 377 MAG ECT

## Sterndrive

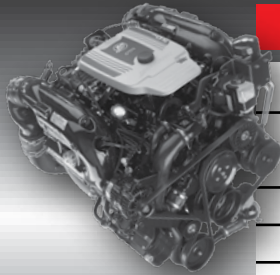

Max-Craft  
**SEACORE**  
system

For full details on this complete corrosion protection system see page 24-27.



SmartCraft Integrated Marine Technology maximizes performance and delivers a greater sense of security with innovative features.



Digital Throttle & Shift utilizes cable-less operation which eliminates helm maintenance and gives instant throttle response.

### SPECIFICATIONS

HP/kW	320 / 235
Max RPM (WOT)	4800 - 5200
Cylinders	V 8
Displacement (CID/L)	377 / 6.2
Bore X Stroke (in/mm)	4.00 x 3.75 / 101 x 95
Compression Ratio	9.0:1
Fuel/Ethanol Tolerance	87 Octane / up to 10% Ethanol
Engine Control System	PCM 09 w/SmartCraft CAN Capability OBD-M Diagnostics & O2 Sensors
Fuel Delivery System	Gen III Cool Fuel
Fuel Injection System	Multi-point Electronic Fuel Injection (MPI)
Induction System	2 Piece Long Runner Intake w/75mm throttle body (80mm w/DTS)
Ignition System	Crank Fired High Voltage Switch w/Knock Control
Charging (Amp/Watt)	65 / 917 Alternator
Water Drain System	3 Point Manual (Bravo)
Exhaust System	EDP Coated Iron Manifold w/ Dry Joint Elbow
Cooling System	Thermostatically Controlled, Raw Water
Accessory Drive System	Serpentine Belt
Recommended Oil	Mercury MerCruiser Full Synthetic 20W-40W, NMMA FCW Rated
Engine Guardian System	Low oil pressure, high coolant temperature, low seawater pressure, low voltage, over-rev control, knock control
Dimensions (LxWxH) in	32 x 30 x 22
Dimensions (LxWxH) mm	814 x 740 x 559
Weight w/Alpha (lbs/kg)	N/A
Weight w/Bravo One (lbs/kg)	1117 / 507
Weight w/Bravo Two (lbs/kg)	1132 / 513
Weight w/Bravo Three (lbs/kg)	1142 / 518
Freshwater Cooling	Standard on SeaCore Model
Digital Throttle & Shift	Optional

## KEY ATTRIBUTES

### ✓ **Sequential Multi-Port Fuel Injection**

Precisely outlines the exact amount of fuel for all driving conditions.

#### **Benefits:**

- *Better throttle response.*
- *Easy starts, regardless of temp.*
- *Increased fuel efficiency.*
- *Smooth, stable idling.*
- *Reduced cost of operation.*

### ✓ **Exclusive GEN III Cool Fuel Module**

Water cooled fuel delivery system provides hi-PSI fuel to the injectors.

- Cools fuel to prevent vapor lock
- Contains water/fuel separating filter

*Reliability with Ease of Maintenance.*



### ✓ **High Output Alternator**

**65 Amps @ Maximum RPM**   **38 Amps @ idle.**

Provides battery charging on demand allowing use of electronics, alarms & other accessories. *Dependability.*



### ✓ **Drive Lube Monitor**

Easy-to-see translucent bottle for checking level of gearcase lubricant with audible level warning. *Provides drive protection and simple maintenance.*

### ✓ **Exclusive Engine Guardian**

Senses potential problems, alerts operator and even reduces engine power when needed. *Peace of Mind; protects your investment.*

#### **Vital functions monitored:**

- Low Oil Pressure
- Low Seawater Pressure
- Engine Temperature
- Low Voltage
- Low Drive Lube
- Over-Rev Control
- Knock Control

## KEY ATTRIBUTES

### ✓ **Dry-Joint Exhaust Design**

Separates cooling water & exhaust at junctions to prevent water leaks from reaching critical engine components.

*Long-Term Endurance with built-in Reliability*

### ✓ **Color-Coded Service Points**

Allows easy checking of fluids levels and convenient filling of reservoirs.

*Ease of Ownership.*

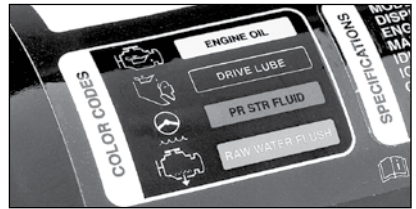

### ✓ **Easy-Maintenance Features**

#### **Top Mount Oil Dipstick**

- Easy to remove or replace
- Fitting allows oil to be pumped out

#### **Front Mount Oil Fill**

#### **Top/Front Mounted Oil Filter**

*Convenient to use and Easy to service.*

### ✓ **Convenient Water Drain Systems**

Simplifies periodic maintenance and allows boaters to extend their boating season into the cooler months. *Ease of Ownership.*

### ✓ **High-Displacement Brass Seawater Pump**

Increases cooling system capacity, more resistant to wear.

*Improved durability.*

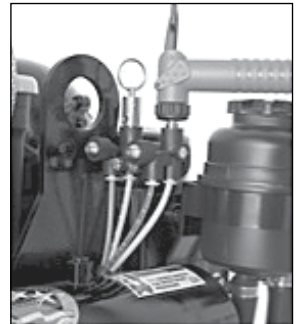

**ADDITIONAL FEATURES / BENEFITS**

<b>MerCruiser's ECT Technology</b>	Multiport Fuel Injection (MPI) PCM09 Control Module Catalyst System (Exhaust Manifolds) <b>Dual Oxygen Sensors on each manifold</b> This system provides excellent performance while producing Super Ultra-Low emission levels
<b>Proven V8 Durability</b>	GM cast iron base engine with long intake runner manifold for better acceleration and handling heavy loads.
<b>High Voltage Ignition</b>	High energy ignition with knock control provides instant starts and more power for performance.
<b>SmartCraft</b>	Delivers information regarding key engine functions from fuel usage, RPM & engine guardian to slow trolling RPM control
<b>EDP (Electro- Deposition Paint) Coating</b>	Featured on the Exhaust manifolds, risers, elbows & Thermostat housings add to corrosion endurance of these components
<b>Power Steering</b>	Reduces steering effort and provides enhanced hull control at all boat speeds
<b>MerCathode Corrosion Protection</b>	Standard on Bravo models, available on Alpha models. This active cathodic corrosion protection system feeds electrons to underwater hardware and drive units.

**AVAILABLE DRIVES****Alpha, Bravo One, Bravo Two, Bravo Three****Visit [mercurymarine.com](http://mercurymarine.com) for details  
on the best performing drives in the world.**

# 8.2 MAG ECT

# Sterndrive

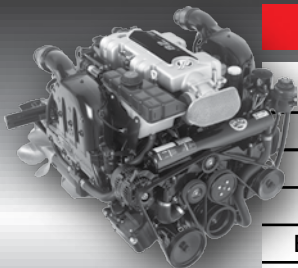

For full details on this complete corrosion protection system see page 24-27.



SmartCraft Integrated Marine Technology maximizes performance and delivers a greater sense of security with innovative features.



Digital Throttle & Shift utilizes cable-less operation which eliminates helm maintenance and gives instant throttle response.

## SPECIFICATIONS

HP/kW	380 / 283
Max RPM (WOT)	4400 - 4800
Cylinders	V 8
Displacement (CID/L)	502 / 8.2
Bore X Stroke (in/mm)	4.47 x 4.00 / 113.5 x 101.6
Compression Ratio	8.75:1
Fuel/Ethanol Tolerance	87 Octane / up to 10% Ethanol
Engine Control System	PCM 09 w/SmartCraft CAN Capability OBD-M Diagnostics & O2 Sensors
Fuel Delivery System	Gen III Cool Fuel
Fuel Injection System	Multi-point Electronic Fuel Injection (MPI)
Induction System	High Inertia Induction System
Ignition System	Distributorless Ignition w/Knock Control
Charging (Amp/Watt)	65 / 917 Alternator
Water Drain System	Single Point Air Actuated
Exhaust System	Tuned Runner Exhaust Manifolds w/316 Stainless Steel Tubular Dry Joint Elbows
Cooling System	Closed Cooling, Long Life 5-Year Anti-freeze, Brass Sea Water Pump
Accessory Drive System	Serpentine Belt, Auto-Tensioner
Recommended Oil	Mercury MerCruiser Full Synthetic 20W-40W, NMMA FCW Rated
Engine Guardian System	Low oil pressure, high coolant temperature, low seawater pressure, low voltage, over- rev control, knock control, high exhaust manifold, temperature, low drive lube
Dimensions (LxWxH) in	35 x 33 x 24
Dimensions (LxWxH) mm	878 x 838 x 610
Weight w/Alpha (lbs/kg)	N/A
Weight w/Bravo One (lbs/kg)	1391 / 631
Weight w/Bravo Two (lbs/kg)	1404 / 637
Weight w/Bravo Three (lbs/kg)	1414 / 641
Full Closed Cooling	Standard
Digital Throttle & Shift	Optional

## KEY ATTRIBUTES

### ✓ **Sequential Multi-Port Fuel Injection**

Precisely outlines the exact amount of fuel for all driving conditions.

#### **Benefits:**

- *Easy starts, regardless of temp.*
- *Smooth, stable idling.*
- *Better throttle response.*
- *Increased fuel efficiency.*
- *Reduced cost of operation.*

### ✓ **Exclusive GEN III Cool Fuel Module**

Water cooled fuel delivery system provides hi-PSI fuel to the injectors.

- Cools fuel to prevent vapor lock
- Contains water/fuel separating filter

**Reliability with Ease of Maintenance.**



### ✓ **High Output Alternator**

**65 Amps @ Maximum RPM**   **38 Amps @ idle.**

Provides battery charging on demand allowing use of electronics, alarms & other accessories. **Dependability.**



### ✓ **Drive Lube Monitor**

Easy-to-see translucent bottle for checking level of gearcase lubricant with audible level warning.

**Provides drive protection and simple maintenance.**

### ✓ **Exclusive Engine Guardian**

Senses potential problems, alerts operator and even reduces engine power when needed. **Peace of Mind; protects your investment.**

#### **Vital functions monitored:**

- High Manifold Temperature
- Low Oil Pressure
- Engine Temperature
- Low Drive Lube
- Low Seawater Pressure
- Low Voltage
- Over-Rev Control
- Knock Control

## KEY ATTRIBUTES

### ✓ **Dry-Joint Exhaust Design**

Separates cooling water & exhaust at junctions to prevent water leaks from reaching critical engine components.

*Long-Term Endurance with built-in Reliability*

### ✓ **Color-Coded Service Points**

Allows easy checking of fluids levels and convenient filling of reservoirs.

*Ease of Ownership.*

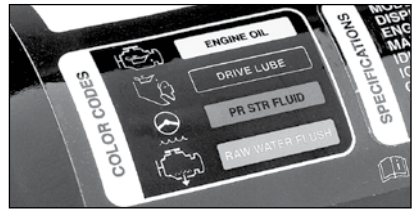

### ✓ **Easy-Maintenance Features**

#### **Top Mount Oil Dipstick**

- Easy to remove or replace
- Fitting allows oil to be pumped out

#### **Front Mount Oil Fill**

#### **Top/Front Mounted Oil Filter**

*Convenient to use and Easy to service.*

### ✓ **Convenient Air Actuated Water Drain System**

Simplifies periodic maintenance and allows boaters to extend their boating season into the cooler months. *Ease of Ownership.*

### ✓ **Full Closed Cooling**

Efficient and durable cooling system.

*Improved durability.*



## ADDITIONAL FEATURES / BENEFITS

<b>MerCruiser's ECT Technology</b>	Multiport Fuel Injection (MPI) PCM09 Control Module Catalyst System (Exhaust Manifolds) <b>Dual Oxygen Sensors on each manifold</b> This system provides excellent performance while producing Super Ultra-Low emission levels
<b>Mercury's Racing V8 Heritage</b>	Large displacement block with the high inertia intake system for delivering torque for strong acceleration and handling heavy loads.
<b>Distributorless Ignition</b>	Computer controlled spark, for more power with a knock. circuit to protect engine from poor quality fuels.
<b>SmartCraft</b>	Delivers information regarding key engine functions from fuel usage, RPM & engine guardian to slow trolling RPM control.
<b>EDP (Electro-Deposition Paint) Coating</b>	Featured on the exhaust manifolds, elbows & thermostat housings add to corrosion endurance of these components.
<b>Power Steering</b>	Reduces steering effort and provides enhanced hull control at all boat speeds.
<b>MerCathode Corrosion Protection</b>	Standard on Bravo models, available on Alpha models. This active cathodic corrosion protection system feeds electrons to underwater hardware and drive units.

## AVAILABLE DRIVES

**Bravo One X, Bravo Two X, Bravo Three X, Bravo One XR, Bravo Three XR**

Visit **[mercurymarine.com](http://mercurymarine.com)** for details on the best performing drives in the world.

# 8.2 MAG HO ECT

# Sterndrive

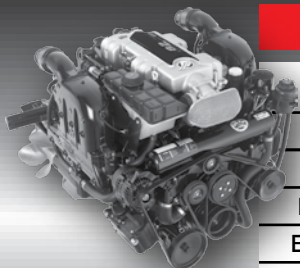

For full details on this complete corrosion protection system see page 24-27.



SmartCraft Integrated Marine Technology maximizes performance and delivers a greater sense of security with innovative features.



Digital Throttle & Shift utilizes cable-less operation which eliminates helm maintenance and gives instant throttle response.

## SPECIFICATIONS

HP/kW	430 / 321
Max RPM (WOT)	4600 - 5000
Cylinders	V 8
Displacement (CID/L)	502 / 8.2
Bore X Stroke (in/mm)	4.47 x 4.00 / 113.5 x 101.6
Compression Ratio	8.75:1
Fuel/Ethanol Tolerance	87 Octane / up to 10% Ethanol
Engine Control System	PCM 09 w/SmartCraft CAN Capability OBD-M Diagnostics & O2 Sensors
Fuel Delivery System	Gen III Cool Fuel
Fuel Injection System	Multi-point Electronic Fuel Injection (MPI)
Induction System	High Inertia Induction System
Ignition System	Distributorless Ignition w/Knock Control
Charging (Amp/Watt)	65 / 917 Alternator
Water Drain System	Single Point Air Actuated
Exhaust System	Tuned Runner Exhaust Manifolds w/316 Stainless Steel Tubular Dry Joint Elbows
Cooling System	Closed Cooling, Long Life 5-Year Anti-freeze, Brass Sea Water Pump
Accessory Drive System	Serpentine Belt, Auto-Tensioner
Recommended Oil	Mercury MerCruiser Full Synthetic 20W-40W, NMMA FCW Rated
Engine Guardian System	Low oil pressure, high coolant temperature, low seawater pressure, low voltage, over- rev control, knock control, high exhaust manifold, temperature, low drive lube
Dimensions (LxWxH) in	35 x 33 x 24
Dimensions (LxWxH) mm	878 x 838 x 610
Weight w/Alpha (lbs/kg)	N/A
Weight w/Bravo One (lbs/kg)	1391 / 631
Weight w/Bravo Two (lbs/kg)	1404 / 637
Weight w/Bravo Three (lbs/kg)	1414 / 641
Full Closed Cooling	Standard
Digital Throttle & Shift	Optional

## KEY ATTRIBUTES

### ✓ **Sequential Multi-Port Fuel Injection**

Precisely outlines the exact amount of fuel for all driving conditions.

#### **Benefits:**

- *Easy starts, regardless of temp.*
- *Smooth, stable idling.*
- *Better throttle response.*
- *Increased fuel efficiency.*
- *Reduced cost of operation.*

### ✓ **Exclusive GEN III Cool Fuel Module**

Water cooled fuel delivery system provides hi-PSI fuel to the injectors.

- Cools fuel to prevent vapor lock
- Contains water/fuel separating filter

*Reliability with Ease of Maintenance.*



### ✓ **High Output Alternator**

**65 Amps @ Maximum RPM**   **38 Amps @ idle.**

Provides battery charging on demand allowing use of electronics, alarms & other accessories. *Dependability.*



### ✓ **Drive Lube Monitor**

Easy-to-see translucent bottle for checking level of gearcase lubricant with audible level warning. *Provides drive protection and simple maintenance.*

### ✓ **Exclusive Engine Guardian**

Senses potential problems, alerts operator and even reduces engine power when needed. *Peace of Mind; protects your investment.*

#### **Vital functions monitored:**

- Low Oil Pressure
- Engine Temperature
- Low Drive Lube
- Low Seawater Pressure
- Low Voltage
- Over-Rev Control
- Knock Control

## KEY ATTRIBUTES

### ✓ **Dry-Joint Exhaust Design**

Separates cooling water & exhaust at junctions to prevent water leaks from reaching critical engine components.

*Long-Term Endurance with built-in Reliability*

### ✓ **Color-Coded Service Points**

Allows easy checking of fluids levels and convenient filling of reservoirs.

*Ease of Ownership.*

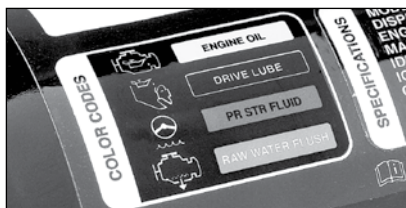

### ✓ **Easy-Maintenance Features**

#### **Top Mount Oil Dipstick**

- Easy to remove or replace
- Fitting allows oil to be pumped out

#### **Front Mount Oil Fill**

#### **Top/Front Mounted Oil Filter**

*Convenient to use and Easy to service.*



### ✓ **Convenient Air Actuated Water Drain System**

Simplifies periodic maintenance and allows boaters to extend their boating season into the cooler months.

*Ease of Ownership.*

### ✓ **High-Displacement Brass Seawater Pump**

Increases cooling system capacity, more resistant to wear.

*Improved durability.*

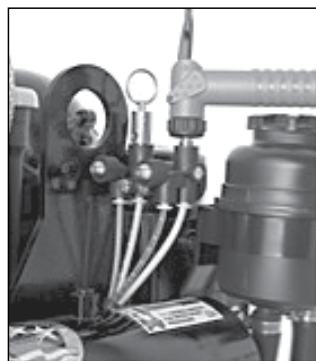

**ADDITIONAL FEATURES / BENEFITS**

<b>MerCruiser's ECT Technology</b>	Multiport Fuel Injection (MPI) PCM09 Control Module Catalyst System (Exhaust Manifolds) <b>Dual Oxygen Sensors on each manifold</b> This system provides excellent performance while producing Super Ultra-Low emission levels
<b>Proven V8 Durability</b>	GM cast iron base engine with long intake runner manifold for better acceleration and handling heavy loads.
<b>Distributorless Ignition</b>	Computer controlled spark, for more power with a knock. circuit to protect engine from poor quality fuels.
<b>SmartCraft</b>	Delivers information regarding key engine functions from fuel usage, RPM & engine guardian to slow trolling RPM control.
<b>EDP (Electro- Deposition Paint) Coating</b>	Featured on the exhaust manifolds, elbows & thermostat housings add to corrosion endurance of these components.
<b>Power Steering</b>	Reduces steering effort and provides enhanced hull control at all boat speeds
<b>MerCathode Corrosion Protection</b>	Standard on Bravo models, available on Alpha models. This active cathodic corrosion protection system feeds electrons to underwater hardware and drive units.

**AVAILABLE DRIVES**

**Bravo One X, Bravo Two X, Bravo Three X, Bravo One XR, Bravo Three XR**

Visit **[mercurymarine.com](http://mercurymarine.com)** for details  
on the best performing drives in the world.

# Water Drain Systems

MerCruiser Models	Easy Drain System	Single-Point Drain System	Three-Point Drain System	Air Actuated Single-Point Drain
3.0 MPI ECT	✓			
4.3 MPI ECT w/Alpha		✓		
4.3 MPI ECT w/Bravo			✓	
4.3 MPI ECT SeaCore or FWC				✓
5.0 MPI ECT w/Alpha		✓		
5.0 MPI ECT w/Bravo			✓	
5.0 MPI ECT SeaCore or FWC				✓
350 MAG MPI ECT w/Alpha		✓		
350 MAG MPI ECT w/Bravo			✓	
350 MAG MPI ECT SeaCore				✓
377 MAG MPI ECT				✓
377 MAG MPI ECT SeaCore				✓
8.2 MAG MPI ECT				✓
8.2 MAG MPI ECT SeaCore				✓
8.2 MAG HO MPI ECT				✓
8.2 MAG HO MPI ECT SeaCore				✓

**Note: On Bravo models, built after Nov. 2010 have 1 additional Blue Drain Plug on Gen III Cool fuel module**

# Drain Plug Locations

## **Single Point Drain**

### **2 Blue Drain Plugs**

1 on thermostat housing (vent), 1 on water distribution housing.

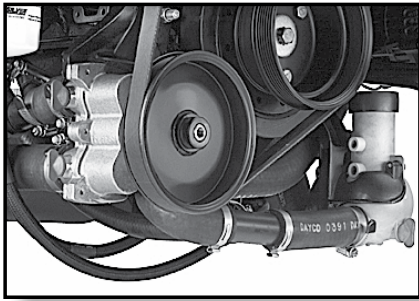

## **Three-Point Manual Drain**

### **3 Blue Drain Plugs**

1 on water distribution housing, 2 in Bravo sea pump.

## **Air Actuated Single-Point Drain**

### **3 Blue Drain Plugs**

1 on heat exchanger to help vent (some engines), 1 on port side drain housing, 2 on sea pump

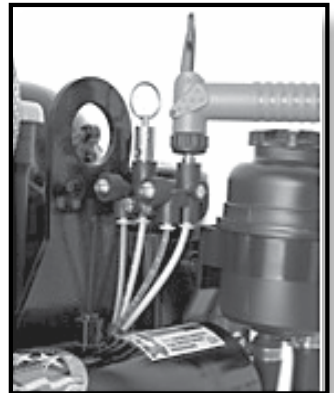



# DRIVES

## MERCUISER

*Alpha One* —

*Bravo One* —

*Bravo One X* —

*Bravo Two* —

*Bravo Two X* —

*Bravo Three* —

*Bravo Three X* —

# Shared Drive Attributes

## KEY ATTRIBUTES

### **Power Trim XD (Hydraulic memory)**

- ✓ Improves hull maneuverability & efficiency.
- ✓ Memory pistons return drive to previous trim position after an underwater impact.

**Controls bow lift for performance & efficiency, optimizes hull maneuverability.**



### **Armored Trim Lines**

- ✓ Braided stainless hoses protect hydraulic system from debris.
- Reliability and long-term endurance.**

### **Trim Limit Switch**

- ✓ Adjustable- allows "up" trim range limit to be set.
- Convenience with Maximum Performance.**

### **Easy to Own and Maintain**

- ✓ Standard Drive Lube Monitor (inside Boat).
- Visually know the gear lube level & condition.**
- ✓ Permanently lubricated U-joint.
- ✓ Maintenance Free Hinge pins.
- ✓ Permanently lubricated gimbal bearing.
- No need to pull drive every season to lubricate.**
- ✓ Greaseable Drive Coupler (inside Boat).
- No need to take boat out of water.**



**Customers keep their boats in at their docks, marinas and even in the islands, where service may be limited. Surveys show that up to 40% of owners do their own maintenance.**

**MerCruiser's low maintenance features help reduce the cost of operation while increasing dependability.**

# Shared Drive Attributes

## KEY ATTRIBUTES

### Corrosion Fighting Built-in

- ✓ XK360 Low Copper Alloy.
- ✓ MercFusion Paint System – Irridite, EDP & Powder Paint.
- ✓ Ultra-Pure Aluminum Anodes & Magnesium Anode Kits.
- ✓ MerCathode - An active cathodic corrosion protection system. Standard on Bravo, available for Alpha models as a kit.
- ✓ 3-Year Limited Corrosion Warranty.



*Reliability and enhanced corrosion fortification.*

### Through-Prop Exhaust

- ✓ Unlike competitors all exhaust is routed through the propeller. Not only is it quieter, but there is no exhaust residue left on the swim platform.

*Best power with least noise and customer comfort while in the water or on the platform near the back of the boat.*

### Mercury Propellers

**The best weapon in your performance arsenal.**

- ✓ A large propeller selection to meet every user's needs.
- ✓ Flow Torque II hubs for endurance and drive protection.
- ✓ Special solid hub props for XR Bravo increases reliability.

*Reliable strong overall performance.*



### Drive & Impact Protection

- ✓ The competition uses "break-away drive couplers" (inside the drive) that fracture in the event of hitting a submerged object with the prop... leaving them hauling a tow back to the dock.

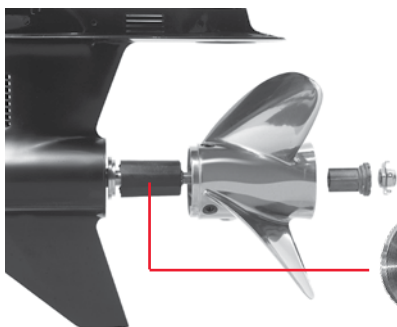

- ✓ Mercury's Flo-Torq. II hub sacrifices itself to prevent gear damage. If your customer can change the prop & hub, they can continue their fun on the water.

*Peace of mind, reliability*



# **Drive** Application Chart

## **Single-Engine Mercruiser Drive Application Chart**

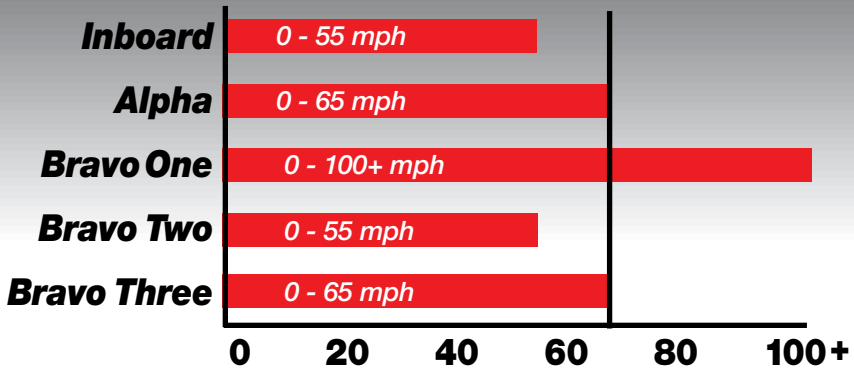

## **Dual-Engine Mercruiser Drive Application Chart**

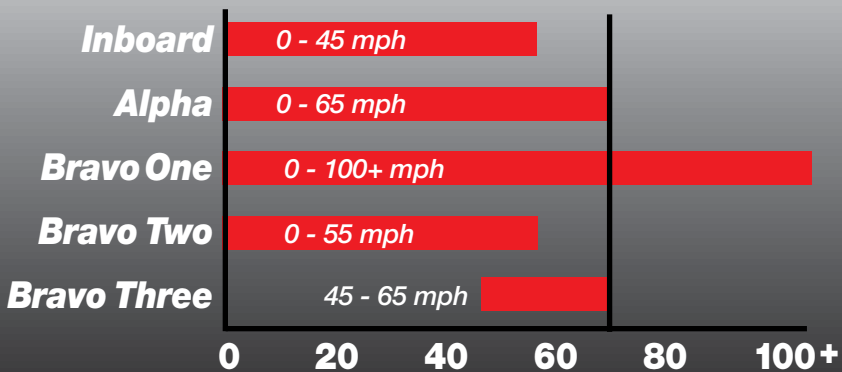

# Application Chart

# Drive

	Runabout	Sport (-60MPH)	Houseboat / Pontoon	Cruiser	Saltwater Fishing	Performance (60+ MPH)
Alpha One	✓	✓	✓	✓	✓	✓
Bravo One	✓	✓	✓	✓	✓	✓
Bravo One X	✓	✓	✓	✓	✓	✓
Bravo Two			✓	✓	✓	
Bravo Two X Diesel			✓	✓	✓	
Bravo Three	✓	✓	✓	✓	✓	✓
Bravo Three X	✓	✓	✓	✓	✓	✓

# Alpha One Drive



## SPECIFICATIONS

Max. Power Cap. (hp/kW)	300/230
Lower Unit Design	Low-drag hydrodynamic torpedo
Max. Prop Diameter (in)	1x16
Water Inlet Location	Strut
Clutch Type	Compact dog clutch w/F-N-R
Available Gear Ratios	1.47, 1.62, 1.81, 2.00, 2.40:1
Counter Rotation	Optional, except 2.40:1 ratio
Upper Unit Gear Set	Precision shimmed, spiral bevel gear
Lower Unit Gear Set	Precision shimmed, spiral bevel gear
Propshaft Material	Heat-treated stainless steel
Propeller Hub Type	Flo-Torq II
Exhaust Outlet	Through prop
Recommended Lube	Mercury High-Performance Gear Lube
Monitoring System	Engine-mounted lube monitor w/audio warning or Engine Guardian
Housing Construction	XK 360 aluminum low-copper alloy
Corrosion Protection	MercFusion paint, anodes & MerCathode kit
Anode Type	Ultra-pure aluminum anodes or magnesium anode kit
Speedometer Pick-up	Integrated into lower housing
Steering System	Single cylinder power steering w/anti-feedback
Steering Range	56 degrees
Power Trim System	Twin-cylinder hydraulic featuring Power Trim XD kick-up return
Trim Limit Switch	Standard - adjustable
Drive Weight (lbs/kg)	85/38



Backed by the industry's only three year limited corrosion failure warranty.

# Drive **Alpha One**

## **Family fun on the Water!**

The Alpha® drive proven tested since 1986, delivers reliable performance in a value package. The lightest drive in the MerCruiser line-up and the most versatile adapting to the broadest range of applications.



### **Simple and Reliable**

- ✓ Proven clutch dog technology.
- ✓ Spiral-cut steel bevel gears for quiet operation.
- ✓ Handles up to 300 horsepower

**Reliable Power!**

### **Smooth Shifting**

- ✓ MPI models utilize a patented engine management program which greatly reduces shift effort with less noise.

**Effortless operation with less noise & vibration.**

### **Performance with Efficiency**

- ✓ Ultra-sleek gearcase that is hydrodynamically efficient.
- ✓ Less drag at all speeds, especially cruise.

**Great performance & Better fuel economy.**

### **Easy to Own and Maintain**

- ✓ Integrated water pump for EZ service & long life.
- ✓ Permanently lubricated U-joint.
- ✓ Maintenance-Free Hinge pins.
- ✓ Permanently lubricated gimbal bearing.

**Spend less time on periodic maintenance and more time on water.**



# Bravo One Drive

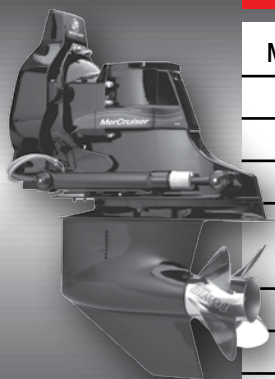

## SPECIFICATIONS

Max. Power Cap. (hp/kW)	400/295
Lower Unit Design	Performance Torpedo
Max. Prop Diameter (in)	1x16
Water Inlet Location	DWP - Torpedo and Strut
Clutch Type	High-Strength Smooth Shift Cone Clutch with F-N-R
Available Gear Ratios	1.36, 1.50, 1.65:1
Counter Rotation	Standard
Upper Unit Gear Set	Precision shimmed assembly w/ near-net forged helical gears
Lower Unit Gear Set	Precision shimmed assembly w/ net forged gears
Propshaft Material	Heat-treated stainless steel
Propeller Hub Type	Flo-Torq or Solid Hub
Exhaust Outlet	Through prop
Recommended Lube	Mercury High-Performance Gear Lube
Monitoring System	Engine-mounted lube monitor w/audio warning or Engine Guardian
Housing Construction	XK 360 aluminum low-copper alloy
Corrosion Protection	MercFusion Paint, anodes & MerCathode kit
Anode Type	Ultra-pure aluminum anodes or magnesium anode kit
Speedometer Pick-up	Integrated into lower housing
Steering System	Single cylinder power steering w/anti-feedback
Steering Range	56 degrees, digital output optional
Power Trim System	Twin-cylinder hydraulic featuring Power Trim XD kick-up return
Trim Limit Switch	Adjustable limit analog or digital
Drive Weight (lbs/kg)	142/64



Backed by the industry's only three year limited corrosion failure warranty.

**Bravo One & One X** - Single-propeller models for single or multiple engines installations to go **over 100 MPH**.

## KEY ATTRIBUTES

### Patented Cone Clutch

- ✓ High-Strength Smooth-Shift with **F-N-R**
- Less shifting effort with positive engagement means more comfort.*

### PermaLube® U-Joint

- ✓ No Maintenance Required
- Lower Cost of Operation.*

### Low Dual-Water Inlets

- ✓ Ensures proper cooling at higher trim angles. *Reliability.*

### Extended Length Torpedo

- ✓ Reduces drag for high-speed boating with predictable handling.
- Top Performance.*

### Longer Skeg

- ✓ Large rudder area for steering response.
- Improves Boat Handling.*

### Heavy-Duty Forged Gears

- ✓ Precision shimmed near-net forged "helical" steel gears
- Provides quiet durable operation.*

### MerCathode

- ✓ An active cathodic corrosion protection system.
- Corrosion protection*

### Stainless Steel Propshaft

### Net Forged Gears

- ✓ Precision Shimmed net forged "Straight Bevel" gears. *Superior Durability.*

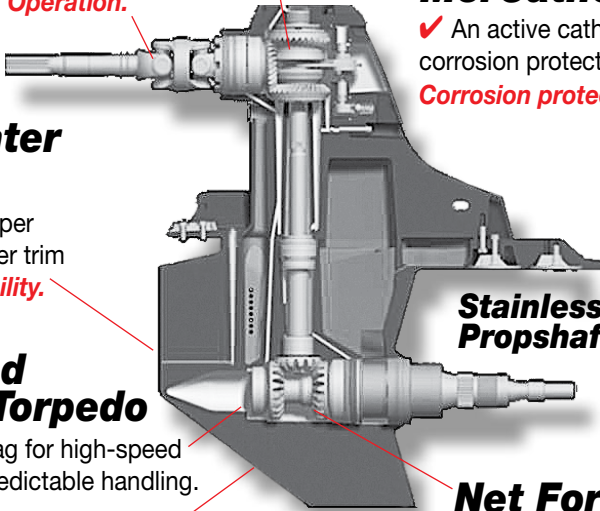

## A Robust design

- ✓ To handle high torque (*Durability*).
- ✓ Deliver exceptional overall performance.
- ✓ While maintaining "**best-in-class**" shifting.

# Bravo One X Drive



## SPECIFICATIONS

Max. Power Cap. (hp/kW)	450/331
Lower Unit Design	Performance Torpedo
Max. Prop Diameter (in)	1x16
Water Inlet Location	DWP - Torpedo and Strut
Clutch Type	High-Strength Smooth Shift Cone Clutch with F-N-R
Available Gear Ratios	1.36, 1.50, 1.65:1
Counter Rotation	Standard
Upper Unit Gear Set	Precision shimmed assemblyw/ near-net forged helical gears, steel chimney bearing supports, reinforced ribbed top cap
Lower Unit Gear Set	Precision shimmed assembly w/ net forged gears
Propshaft Material	Heat-treated stainless steel
Propeller Hub Type	Flo-Torq or Solid Hub
Exhaust Outlet	Low restriction through transom or prop
Recommended Lube	Mercury High-Performance Gear Lube
Monitoring System	Drive lube monitor w/audio warning or Engine Guardian
Housing Construction	XK 360 aluminum low-copper alloy
Corrosion Protection	MercFusion Paint, anodes & MerCathode kit
Anode Type	Ultra-pure aluminum anodes or magnesium anode kit
Speedometer Pick-up	Integrated into lower housing
Steering System	Single cylinder power steering w/anti-feedback
Steering Range	56 degrees, digital output optional
Power Trim System	Twin-cylinder hydraulic featuring Power Trim XD kick-up return
Trim Limit Switch	Adjustable limit analog or digital
Drive Weight (lbs/kg)	142/64



Backed by the industry's only three year limited corrosion failure warranty.

# Drive **Bravo One X**

**Bravo One & One X** - Single-propeller models for single or multiple engines installations to go **over 100 MPH**.

## KEY ATTRIBUTES

### **Patented Cone Clutch**

- ✓ High-Strength Smooth-Shift with *F-N-R*
- Less shifting effort with positive engagement means more comfort.*

### **PermaLube® U-Joint**

- ✓ No Maintenance Required
- Lower Cost of Operation.*

### **Low Dual-Water Inlets**

- ✓ Ensures proper cooling at higher trim angles. *Reliability.*

### **Extended Length Torpedo**

- ✓ Reduces drag for high-speed boating with predictable handling. *Top Performance.*

### **Longer Skeg**

- ✓ Large rudder area for steering response. *Improves Boat Handling.*

### **Heavy-Duty Forged Gears**

- ✓ Precision shimmed near-net forged “helical” steel gears
- Provides quiet durable operation.*

### **MerCathode**

- ✓ An active cathodic corrosion protection system. *Corrosion protection*

### **Stainless Steel Propshaft**

### **Net Forged Gears**

- ✓ Precision Shimmed net forged “Straight Bevel” gears. *Superior Durability.*

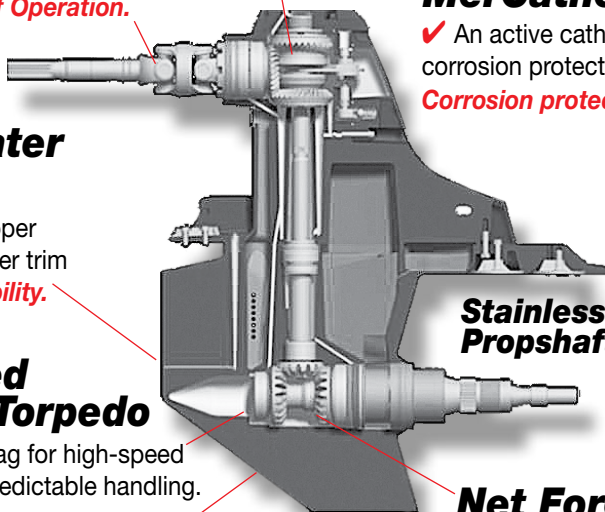

## **A Robust design**

- ✓ *To handle high torque (Durability).*
- ✓ *Deliver exceptional overall performance.*
- ✓ *While maintaining “best-in-class” shifting.*

# Bravo Two Drive



## SPECIFICATIONS

Max. Power Cap. (hp/kW)	400/295
Lower Unit Design	Extended Length Strut
Max. Prop Diameter (in)	1x20
Water Inlet Location	Strut
Clutch Type	High-Strength Smooth Shift Cone Clutch with F-N-R
Available Gear Ratios	1.81, 2.00, 2.20:1
Counter Rotation	Standard
Upper Unit Gear Set	Precision shimmed assembly w/ near-net forged helical gears
Lower Unit Gear Set	Precision shimmed assembly w/ net forged gears
Propshaft Material	Heat-treated stainless steel
Propeller Hub Type	Rubber Hub
Exhaust Outlet	Through prop
Recommended Lube	Mercury High-Performance Gear Lube
Monitoring System	Engine-mounted lube monitor w/audio warning or Engine Guardian
Housing Construction	XK 360 aluminum low-copper alloy
Corrosion Protection	MercFusion Paint, anodes & MerCathode kit
Anode Type	Ultra-pure aluminum anodes or magnesium anode kit
Speedometer Pick-up	Integrated into lower housing
Steering System	Single cylinder power steering w/anti-feedback
Steering Range	56 degrees
Power Trim System	Twin-cylinder hydraulic featuring Power Trim XD kick-up return
Trim Limit Switch	Adjustable limit analog or digital
Drive Weight (lbs/kg)	157/71



Backed by the industry's only three year limited corrosion failure warranty.

# Drive **Bravo Two**

**Bravo Two & Two X** - Single-propeller models  
for single or multiple engines installations.

## KEY ATTRIBUTES

### Patented Cone Clutch

- ✓ High-Strength Smooth-Shift with *F-N-R*  
*Less shifting effort with positive engagement means more comfort.*

### PermaLube® U-Joint

- ✓ No Maintenance Required  
*Lower Cost of Operation.*

### Longer Length Design

- ✓ Allows for 20" diameter props for increased thrust.

### Large Diameter Torpedo

- ✓ Improves hull maneuverability for predictable boat handling.  
*More Thrust.*

### Longer Skeg

- ✓ Large rudder area for steering response.  
*Improves Boat Handling.*

### Heavy-Duty Forged Gears

- ✓ Precision shimmed near-net forged "helical" steel gears  
*Provides quiet durable operation.*

### MerCathode

- ✓ An active cathodic corrosion protection system.  
*Corrosion protection*

### Large Diameter Propshaft

### Net Forged Gears

- ✓ Precision Shimmed net forged "Straight Bevel" gears. *Superior Durability.*

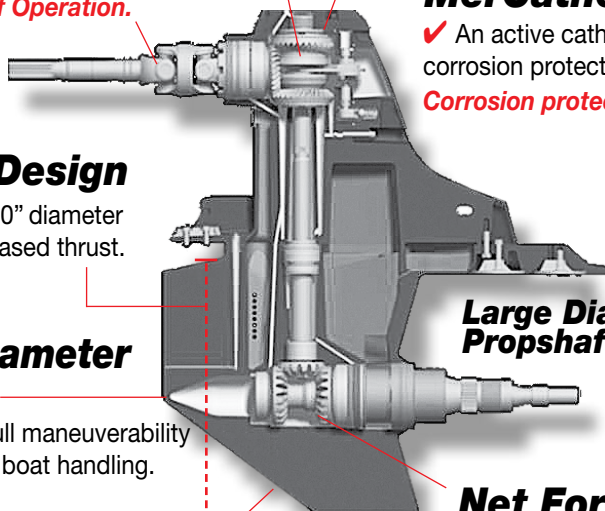

## **A Robust design**

- ✓ To handle high torque (Durability).
- ✓ Deliver exceptional overall performance.
- ✓ While maintaining "best-in-class" shifting.

# Bravo Two X

## Drive



### SPECIFICATIONS

Max. Power Cap. (hp/kW)	450/332
Lower Unit Design	Performance Torpedo
Max. Prop Diameter (in)	1x20
Water Inlet Location	Strut
Clutch Type	High-Strength Smooth Shift Cone Clutch with F-N-R
Available Gear Ratios	1.81, 2.00, 2.20:1
Counter Rotation	Standard
Upper Unit Gear Set	Precision shimmed assembly w/ near-net forged helical gears, steel chimney bearing supports, reinforced ribbed top cap
Lower Unit Gear Set	Precision shimmed assembly w/ net forged gears
Propshaft Material	Heat-treated stainless steel
Propeller Hub Type	Rubber Hub
Exhaust Outlet	Low restriction through transom or prop
Recommended Lube	Mercury High-Performance Gear Lube
Monitoring System	Drive lube monitor w/audio warning or Engine Guardian
Housing Construction	XK 360 aluminum low-copper alloy
Corrosion Protection	MercFusion Paint, anodes & MerCathode kit
Anode Type	Ultra-pure aluminum anodes or magnesium anode kit
Speedometer Pick-up	Integrated into lower housing
Steering System	Single cylinder power steering w/anti-feedback
Steering Range	56 degrees
Power Trim System	Twin-cylinder hydraulic featuring Power Trim XD kick-up return
Trim Limit Switch	Adjustable limit analog or digital
Drive Weight (lbs/kg)	157/71



Backed by the industry's only three year limited corrosion failure warranty.

# Drive **Bravo Two X**

**Bravo Two & Two X** - Single-propeller models  
for single or multiple engines installations.

## KEY ATTRIBUTES

### Patented Cone Clutch

- ✓ High-Strength Smooth-Shift with *F-N-R*  
*Less shifting effort with positive engagement means more comfort.*

### PermaLube® U-Joint

- ✓ No Maintenance Required  
*Lower Cost of Operation.*

### Longer Length Design

- ✓ Allows for 20" diameter props for increased thrust.

### Large Diameter Torpedo

- ✓ Improves hull maneuverability for predictable boat handling.  
*More Thrust.*

### Longer Skeg

- ✓ Large rudder area for steering response.  
*Improves Boat Handling.*

### Heavy-Duty Forged Gears

- ✓ Precision shimmed near-net forged "helical" steel gears  
*Provides quiet durable operation.*

### MerCathode

- ✓ An active cathodic corrosion protection system.  
*Corrosion protection*

### Large Diameter Propshaft

### Net Forged Gears

- ✓ Precision Shimmed net forged "Straight Bevel" gears. *Superior Durability.*

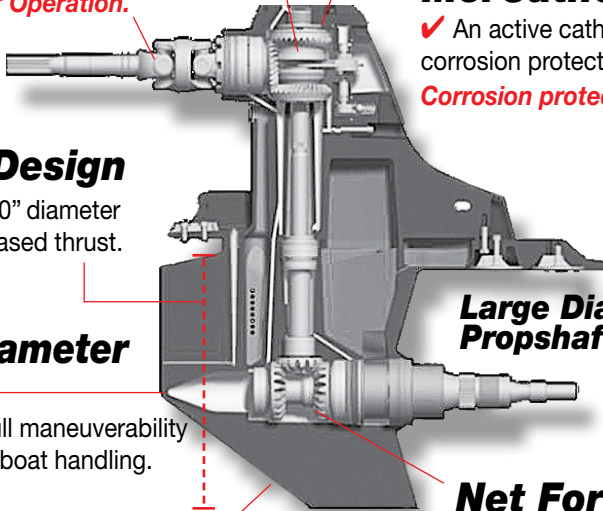

## **A Robust design**

- ✓ To handle high torque (*Durability*).
- ✓ Deliver exceptional overall performance.
- ✓ While maintaining "**best-in-class**" shifting.

# Bravo Three Drive

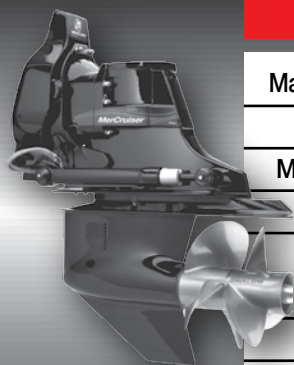

## SPECIFICATIONS

Max. Power Cap. (hp/kW)	400/295
Lower Unit Design	Extended Length Strut
Max. Prop Diameter (in)	2x16
Water Inlet Location	Strut
Clutch Type	High-Strength Smooth Shift Cone Clutch with F-N-R
Available Gear Ratios	1.81, 2.00, 2.20, 2.43:1
Counter Rotation	Twin Prop
Upper Unit Gear Set	Precision shimmed assembly w/ near-net forged helical gears
Lower Unit Gear Set	Precision shimmed assembly w/ forged gears w/twin counter rotating prop shafts
Propshaft Material	Heat-treated stainless steel
Propeller Hub Type	Solid
Exhaust Outlet	Through Prop
Recommended Lube	Mercury High-Performance Gear Lube
Monitoring System	Drive lube monitor w/audio warning or Engine Guardian
Housing Construction	XK 360 aluminum low-copper alloy
Corrosion Protection	MercFusion Paint, anodes & MerCathode kit
Anode Type	Ultra-pure aluminum anodes or magnesium anode kit
Speedometer Pick-up	Integrated into lower housing
Steering System	Single cylinder power steering w/anti-feedback
Steering Range	56 degrees
Power Trim System	Twin-cylinder hydraulic featuring Power Trim XD kick-up return
Trim Limit Switch	Adjustable limit analog or digital
Drive Weight (lbs/kg)	167/76



Backed by the industry's only three year limited corrosion failure warranty.

# Drive

# Bravo Three

**Bravo Three** - Dual counter-rotating propeller models for single or twin installations.

## KEY ATTRIBUTES

### Patented Cone Clutch

- ✓ High-Strength Smooth-Shift with *F-N-R*
- Less shifting effort with positive engagement means more comfort.*

### PermaLube® U-Joint

- ✓ No Maintenance Required
- Lower Cost of Operation.*

### Net Forged Straight Bevel Gears

- ✓ Precision shimmed.
- Superior Durability.*

### Dual Propellers

- ✓ Provides optimum handling and acceleration.
- Great driving experience.*

### Heavy-Duty Forged Gears

- ✓ Precision shimmed near-net forged "helical" steel gears
- Provides quiet durable operation.*

### MerCathode

- ✓ An active cathodic corrosion protection system.
- Corrosion protection*

### Extended Anti-Ventilation Plate

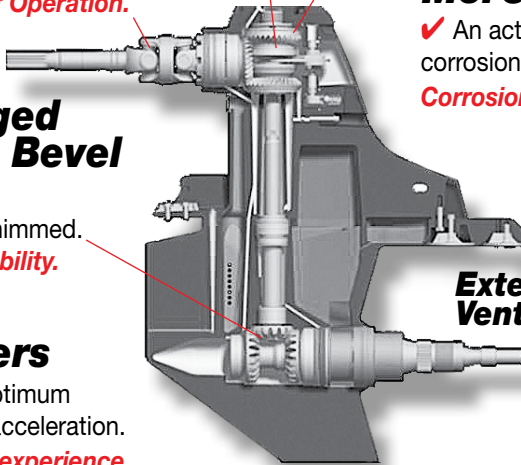

## Bravo Three Benefits

**Helps the boat get on plane without the tendency for the bow to rise.**

- ✓ Can see while boat is getting on plane.
- ✓ 30% Quicker acceleration.
- ✓ Better for pulling skiers or tubers .

**Allows the hull to maintain a planing attitude at a lower speeds.**

- ✓ No steering torque as compared to single prop.
- ✓ Improves hull maneuverability - comfort.
- ✓ Better efficiency for reduced cost of operation .
- ✓ No Prop blow-out in tight turns.

# Bravo Three X Drive

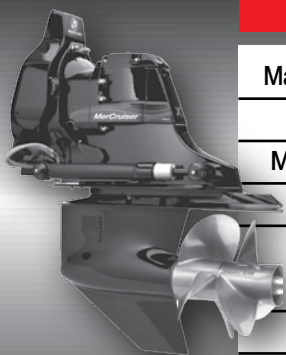

## SPECIFICATIONS

Max. Power Cap. (hp/kW)	450/332
Lower Unit Design	Large Rudder Area Twin Prop
Max. Prop Diameter (in)	2x16
Water Inlet Location	Strut
Clutch Type	High-Strength Smooth Shift Cone Clutch with F-N-R
Available Gear Ratios	1.81, 2.00, 2.20:1
Counter Rotation	Twin Prop
Upper Unit Gear Set	Precision shimmed assembly w/ near-net forged helical gears, steel chimney bearing supports, reinforced ribbed top cap
Lower Unit Gear Set	Precision shimmed assembly w/ forged gears w/twin counter rotating prop shafts
Propshaft Material	Heat-treated stainless steel
Propeller Hub Type	Solid
Exhaust Outlet	Low restriction through transom or prop
Recommended Lube	Mercury High-Performance Gear Lube
Monitoring System	Drive lube monitor w/audio warning or Engine Guardian
Housing Construction	XK 360 aluminum low-copper alloy
Corrosion Protection	MercFusion Paint, anodes & MerCathode kit
Anode Type	Ultra-pure aluminum anodes or magnesium anode kit
Speedometer Pick-up	Integrated into lower housing
Steering System	Single cylinder power steering w/anti-feedback
Steering Range	56 degrees
Power Trim System	Twin-cylinder hydraulic featuring Power Trim XD kick-up return
Trim Limit Switch	Adjustable limit analog or digital
Drive Weight (lbs/kg)	167/76



Backed by the industry's only three year limited corrosion failure warranty.

# Drive **Bravo Three X**

**Bravo Three X** - Dual counter-rotating propeller models for single or twin installations.

## KEY ATTRIBUTES

### **Patented Cone Clutch**

✓ High-Strength Smooth-Shift with *F-N-R*

*Less shifting effort with positive engagement means more comfort.*

### **Reinforced Top Cap**

✓ Ribbed for cooling to support bearings under high load.

*Reliability.*

### **Billet Anodized Bearing Carrier**

✓ Precision shimmed.

*Superior Durability.*

### **Net Forged Straight Bevel Gears**

✓ Precision shimmed.

*Superior Durability.*

### **Heavy-Duty Forged Gears**

✓ Precision shimmed near-net forged "helical" steel gears

*Provides quiet durable operation.*

### **MerCathode**

✓ An active cathodic corrosion protection system.

*Corrosion protection*

### **Extended Anti-Ventilation Plate**

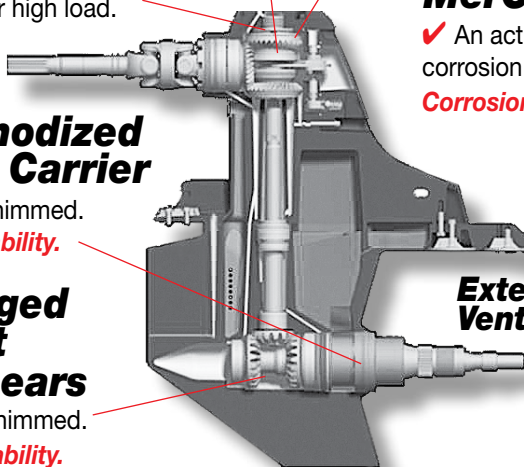

## **Bravo Three Benefits**

**Helps the boat get on plane without the tendency for the bow to rise.**

- ✓ Can see while boat is getting on plane.
- ✓ 30% Quicker acceleration.
- ✓ Better for pulling skiers or tubers .

**Allows the hull to maintain a planing attitude at a lower speeds.**

- ✓ No steering torque as compared to single prop.
- ✓ Improves hull maneuverability - comfort.
- ✓ Better efficiency for reduced cost of operation .
- ✓ No Prop blow-out in tight turns.



# **INBOARD & TOW SPORTS**

**MerCruiser Inboards ECT** —

**5.7 Horizon DTS** —

**6.2 Horizon DTS** —

**8.2 Horizon (375hp) DTS** —

**8.2 H.O. (425hp) DTS** —

**MerCruiser Tow Sports ECT** —

**5.7 MPI** —

**Scorpion 350 DTS** —

# 5.7 Horizon DTS ECT Inboard



## SPECIFICATIONS

HP/kW	300 / 224
Max RPM (WOT)	4600 - 5000
Cylinders	V 8
Displacement (CID/L)	350 / 5.7
Bore X Stroke (in/mm)	4.00 x 3.48 / 101 x 88
Compression Ratio	9.4:1
Fuel/Ethanol Tolerance	87 Octane / up to 10% Ethanol
Engine Control System	PCM 09 w/SmartCraft CAN Capability, OBD-M Diagnostics, & O2 Sensors
Fuel Delivery System	Gen III Cool Fuel
Fuel Injection System	Multi-point Electronic Fuel Injection (MPI)
Induction System	2 Piece Long Runner Intake w/80mm throttle body
Ignition System	Crank Fired High Voltage Switch w/Knock Control
Charging (Amp/Watt)	65 / 917 Alternator
Water Drain System	Single-Point Air Actuated
Exhaust System	EDP Coated Exhaust Manifolds with Dry-Joint Design Through Prop
Emission Control	Standard
Cooling System	Closed Cooling Long Life 5-year anti-freeze brass seawater pump
Accessory Drive System	Serpentine Belt
Recommended Oil	Mercury MerCruiser Full Synthetic 20W-40W, NMMA FCW Rated
Engine Guardian System	Low oil pressure, high coolant temperature, low seawater pressure, low voltage, over-rev control, knock control
Dimensions (LxWxH) in	43 x 30 x 22
Dimensions (LxWxH) mm	1092 x 740 x 559
Weight w/Velvet Drive (lbs/kg)	948 / 431
Digital Throttle & Shift	Standard
Horizon Package Extras	Standard closed cooling with 5 year coolant for longer engine life Convenient single-point water drain system for simple maintenance and extended boating seasons. Additional limited year warranty



SmartCraft Integrated Marine Technology maximizes performance and delivers a greater sense of security with innovative features.



Digital Throttle & Shift utilizes cable-less operation which eliminates helm maintenance and gives instant throttle response.

# Inboard **5.7 Horizon DTS ECT**

## KEY ATTRIBUTES

<b>MerCruiser's ECT Technology</b>	<b>PCM 09 Control module - Catalyst System (Exhaust Manifolds) - Pre &amp; Post Oxygen sensors</b> This system provides excellent performance while producing Super Ultra-Low emissions levels.
<b>Proven V8 Durability</b>	GM cast iron base engine with long intake runner manifold for better acceleration and handling heavy loads.
<b>Multi-Port Fuel Injection</b>	<b>Precisely outlines the exact amount of fuel.</b> Easy starting, regardless of temperature with smooth, stable idling and instant throttle response. Increased fuel efficiency. Reduced cost of operation.
<b>Gen III Cool Fuel Module</b>	Prevents fuel overheating & vapor lock for added reliability.
<b>DTS System Digital Throttle &amp; Shift</b>	Provides reliable, precise shifts and silky-smooth throttle control. <b>Automatic engine synchronization.</b>
<b>SmartCraft</b>	Delivers information regarding key engine functions from fuel usage, RPM & engine guardian.
<b>65 Amp Alternator</b>	Provides plenty of power for onboard electronics.
<b>Easy Water Drain System</b>	Extends boating season and user friendly
<b>EDP</b>	<b>(Electro-Deposition Paint Coating)</b> Featured on exhaust manifolds, risers & elbows to resist temperature and corrosion for long life.

## AVAILABLE DRIVES

**ZF 63A Down Angle, ZF 63IV V-Drive**

**Exclusive Transmission Guardian** monitors temperature & clutch pack pressure and protects transmission from damage due to overheating or clutch slippage.

# 6.2 Horizon DTS ECT Inboard



## SPECIFICATIONS

HP/kW	320 / 239
Max RPM (WOT)	4600 - 5000
Cylinders	V 8
Displacement (CID/L)	377 / 6.2
Bore X Stroke (in/mm)	4.00 x 3.75 / 101 x 95
Compression Ratio	9.0:1
Fuel/Ethanol Tolerance	87 Octane / up to 10% Ethanol
Engine Control System	PCM 09 w/SmartCraft CAN Capability, OBD-M Diagnostics, & O2 Sensors
Fuel Delivery System	Gen III Cool Fuel
Fuel Injection System	Multi-point Electronic Fuel Injection (MPI)
Induction System	2 Piece Long Runner Intake w/80mm throttle body
Ignition System	Crank Fired High Voltage Switch w/Knock Control
Charging (Amp/Watt)	65 / 917 Alternator
Water Drain System	Single-Point Air Actuated
Exhaust System	EDP Coated Exhaust Manifolds with Dry-Joint Design Through Prop
Emission Control	Standard
Cooling System	Closed Cooling Long Life 5-year anti-freeze brass seawater pump
Accessory Drive System	Serpentine Belt
Recommended Oil	Mercury MerCruiser Full Synthetic 20W-40W, NMMA FCW Rated
Engine Guardian System	Low oil pressure, high coolant temperature, low seawater pressure, low voltage, over-rev control, knock control, transmission temperature
Dimensions (LxWxH) in	43 x 30 x 22
Dimensions (LxWxH) mm	1092 x 740 x 559
Weight w/Velvet Drive (lbs/kg)	948 / 431
Digital Throttle & Shift	Standard
Horizon Package Extras	Standard closed cooling with 5 year coolant for longer engine life Convenient single-point water drain system for simple maintenance and extended boating seasons. Additional limited year warranty



SmartCraft Integrated Marine Technology maximizes performance and delivers a greater sense of security with innovative features.



Digital Throttle & Shift utilizes cable-less operation which eliminates helm maintenance and gives instant throttle response.

# Inboard **6.2 Horizon DTS ECT**

## KEY ATTRIBUTES

<b>MerCruiser's ECT Technology</b>	<b>PCM09 Control module - Catalyst System (Exhaust Manifolds) - Pre &amp; Post Oxygen sensors</b> This system provides excellent performance while producing Super Ultra-Low emissions levels.
<b>Proven V8 Durability</b>	GM cast iron base engine with long intake runner manifold for better acceleration and handling heavy loads.
<b>Multi-Port Fuel Injection</b>	<b>Precisely outlines the exact amount of fuel.</b> Easy starting, regardless of temperature with smooth, stable idling and instant throttle response. Increased fuel efficiency. Reduced cost of operation.
<b>Gen III Cool Fuel Module</b>	Prevents fuel overheating & vapor lock for added reliability.
<b>DTS System Digital Throttle &amp; Shift</b>	Provides reliable, precise shifts and silky-smooth throttle control. <b>Automatic engine synchronization.</b>
<b>SmartCraft</b>	Delivers information regarding key engine functions from fuel usage, RPM & engine guardian.
<b>65 Amp Alternator</b>	Provides plenty of power for onboard electronics.
<b>Easy Water Drain System</b>	Extends boating season and user friendly
<b>EDP</b>	<b>(Electro-Deposition Paint Coating)</b> Featured on exhaust manifolds, risers & elbows to resist temperature and corrosion for long life.

## AVAILABLE DRIVES

**ZF 63A Down Angle, ZF 63IV V-Drive**

**Exclusive Transmission Guardian** monitors temperature & clutch pack pressure and protects transmission from damage due to overheating or clutch slippage.

# 8.2 Horizon (375hp) DTS ECT Inboard

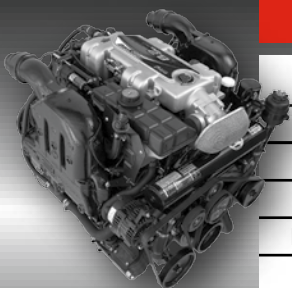

**SEACORE**  
system

For full details on this complete corrosion protection system see pages 24-27.



SmartCraft Integrated Marine Technology maximizes performance and delivers a greater sense of security with innovative features.



Digital Throttle & Shift utilizes cable-less operation which eliminates helm maintenance and gives instant throttle response.

## SPECIFICATIONS

HP/kW	375 / 280
Max RPM (WOT)	4200 - 4600
Cylinders	V 8
Displacement (CID/L)	502 / 8.2
Bore X Stroke (in/mm)	4.47 x 4.00 / 113.5 x 101.6
Compression Ratio	8.75:1
Fuel/Ethanol Tolerance	87 Octane / up to 10% Ethanol
Engine Control System	PCM 09 w/SmartCraft CAN Capability OBD-M Diagnostics & O2 Sensors
Fuel Delivery System	Gen III Cool Fuel
Fuel Injection System	Multi-point Electronic Fuel Injection (MPI) (Sequential Fuel Injection w/DTS)
Induction System	High Inertia Induction System
Ignition System	Distributorless Ignition w/Knock Control
Charging (Amp/Watt)	65 / 917 Alternator
Water Drain System	Single-Point Air Actuated
Exhaust System	Tuned Runner Exhaust Manifolds w/316 Stainless Steel Tubular Dry Joint Elbows
Cooling System	Closed Cooling, Long Life 5-Year Anti-freeze, Brass Seawater Pump
Accessory Drive System	Serpentine Belt, Auto-Tensioner
Recommended Oil	Mercury MerCruiser Full Synthetic 20W-40W, NMMA FCW Rated
Engine Guardian System	Low oil pressure, high coolant temperature, low seawater pressure, low voltage, over- rev control, knock control, high exhaust manifold, temperature, low drive lube
Dimensions (LxWxH) in	35 x 33 x 24
Dimensions (LxWxH) mm	878 x 838 x 610
Weight Engine Only (lbs/kg)	1159 / 526
Full Closed Cooling	Standard
Digital Throttle & Shift	Standard

# Inboard **8.2** Horizon (375hp) DTS ECT

## KEY ATTRIBUTES

<b>MerCruiser's ECT Technology</b>	<b>PCM 09 Control module - Catalyst System (Exhaust Manifolds) - Pre &amp; Post Oxygen sensors</b> This system provides excellent performance while producing Super Ultra-Low emissions levels.
<b>Proven V8 Durability</b>	GM cast iron base engine with long intake runner manifold for better acceleration and handling heavy loads.
<b>Multi-Port Fuel Injection</b>	<b>Precisely outlines the exact amount of fuel.</b> Easy starting, regardless of temperature with smooth, stable idling and instant throttle response. Increased fuel efficiency. Reduced cost of operation.
<b>Gen III Cool Fuel Module</b>	Prevents fuel overheating & vapor lock for added reliability.
<b>DTS System Digital Throttle &amp; Shift</b>	Provides reliable, precise shifts and silky-smooth throttle control. <b>Automatic engine synchronization.</b>
<b>SmartCraft</b>	Delivers information regarding key engine functions from fuel usage, RPM & engine guardian.
<b>65 Amp Alternator</b>	Provides plenty of power for onboard electronics.
<b>Easy Water Drain System</b>	Extends boating season and user friendly
<b>EDP</b>	<b>(Electro-Deposition Paint Coating)</b> Featured on exhaust manifolds, risers & elbows to resist temperature and corrosion for long life.

## AVAILABLE DRIVES

**ZF 63A Down Angle, ZF 63IV V-Drive**

**Exclusive Transmission Guardian** monitors temperature & clutch pack pressure and protects transmission from damage due to overheating or clutch slippage.

# 8.2 H.O. (425hp) DTS ECT Inboard

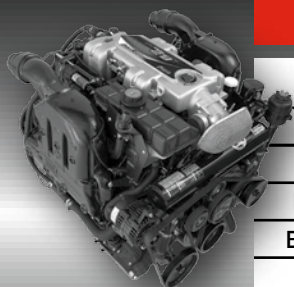

For full details on this complete corrosion protection system see page 24-27.



SmartCraft Integrated Marine Technology maximizes performance and delivers a greater sense of security with innovative features.



Digital Throttle & Shift utilizes cable-less operation which eliminates helm maintenance and gives instant throttle response.

## SPECIFICATIONS

HP/kW	425 / 317
Max RPM (WOT)	4400 - 4800
Cylinders	V 8
Displacement (CID/L)	502 / 8.2
Bore X Stroke (in/mm)	4.47 x 4.00 / 113.5 x 101.6
Compression Ratio	8.75:1
Fuel/Ethanol Tolerance	87 Octane / up to 10% Ethanol
Engine Control System	PCM 09 w/SmartCraft CAN Capability OBD-M Diagnostics & O2 Sensors
Fuel Delivery System	Gen III Cool Fuel
Fuel Injection System	Multi-point Electronic Fuel Injection (MPI) (Sequential Fuel Injection w/DTS)
Induction System	High Inertia Induction System
Ignition System	Distributorless Ignition w/Knock Control
Charging (Amp/Watt)	65 / 917 Alternator
Water Drain System	Single-Point Air Actuated
Exhaust System	Tuned Runner Exhaust Manifolds w/316 Stainless Steel Tubular Dry Joint Elbows
Cooling System	Closed Cooling, Long Life 5-Year Anti-freeze, Brass Seawater Pump
Accessory Drive System	Serpentine Belt, Auto-Tensioner
Recommended Oil	Mercury MerCruiser Full Synthetic 20W-40W, NMMA FCW Rated
Engine Guardian System	Low oil pressure, high coolant temperature, low seawater pressure, low voltage, over- rev control, knock control, high exhaust manifold, temperature, low drive lube
Dimensions (LxWxH) in	35 x 33 x 24
Dimensions (LxWxH) mm	878 x 838 x 610
Weight Engine Only (lbs/kg)	1159 / 526
Full Closed Cooling	Standard
Digital Throttle & Shift	Standard

# Inboard 8.2 H.O. (425hp) DTS ECT

## KEY ATTRIBUTES

<b>MerCruiser's ECT Technology</b>	<b>PCM 09 Control module - Catalyst System (Exhaust Manifolds) - Pre &amp; Post Oxygen sensors</b> This system provides excellent performance while producing Super Ultra-Low emissions levels.
<b>Proven V8 Durability</b>	GM cast iron base engine with long intake runner manifold for better acceleration and handling heavy loads.
<b>Multi-Port Fuel Injection</b>	<b>Precisely outlines the exact amount of fuel.</b> Easy starting, regardless of temperature with smooth, stable idling and instant throttle response. Increased fuel efficiency. Reduced cost of operation.
<b>Gen III Cool Fuel Module</b>	Prevents fuel overheating & vapor lock for added reliability.
<b>DTS System Digital Throttle &amp; Shift</b>	Provides reliable, precise shifts and silky-smooth throttle control. <b>Automatic engine synchronization.</b>
<b>SmartCraft</b>	Delivers information regarding key engine functions from fuel usage, RPM & engine guardian.
<b>65 Amp Alternator</b>	Provides plenty of power for onboard electronics.
<b>Easy Water Drain System</b>	Extends boating season and user friendly
<b>EDP</b>	<b>(Electro-Deposition Paint Coating)</b> Featured on exhaust manifolds, risers & elbows to resist temperature and corrosion for long life.

## AVAILABLE DRIVES

**ZF 63A Down Angle, ZF 63IV V-Drive**

**Exclusive Transmission Guardian** monitors temperature & clutch pack pressure and protects transmission from damage due to overheating or clutch slippage.

# 5.7 MPI ECT **Tow Sports**

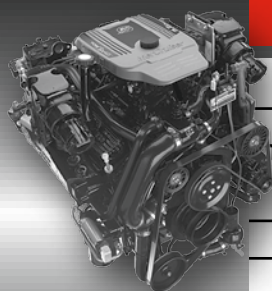

## SPECIFICATIONS

HP/kW	315 / 235
Max RPM (WOT)	4600 - 5000
Cylinders	V 8
Displacement (CID/L)	350 / 5.7
Bore X Stroke (in/mm)	4.00 x 3.48 / 101 x 88
Compression Ratio	9.4:1
Fuel/Ethanol Tolerance	87 Octane / up to 10% Ethanol
Engine Control System	PCM 09 w/SmartCraft CAN Capability, OBD-M Diagnostics, & O2 Sensors
Fuel Delivery System	Gen III Cool Fuel w/Boost Pump
Fuel Injection System	Multi-point Electronic Fuel Injection (MPI)
Induction System	2 Piece Long Runner Intake w/75mm throttle body
Ignition System	Crank Fired High Voltage Switch w/Knock Control
Charging (Amp/Watt)	65 / 917 Alternator
Water Drain System	Three-Point Manual, Optional Air Actuated
Exhaust System	EDP Coated Exhaust Manifolds with Dry-Joint Design Through Prop
Emission Control	Standard
Cooling System	Thermostatically Controlled, Raw Water, Brass Seawater Pump
Accessory Drive System	Serpentine Belt
Recommended Oil	Mercury MerCruiser Full Synthetic 20W-40W, NMMA FCW Rated
Engine Guardian System	Low oil pressure, high coolant temperature, low seawater pressure, low voltage, over-rev control, knock control
Dimensions (LxWxH) in	43 x 30 x 22
Dimensions (LxWxH) mm	1092 x 740 x 559
Weight w/Velvet Drive (lbs/kg)	813 / 369
Full Closed Cooling System	N/A



SmartCraft Integrated Marine Technology maximizes performance and delivers a greater sense of security with innovative features.

# Tow Sports

# 5.7 MPI ECT

## KEY ATTRIBUTES

<b>MerCruiser's ECT Technology</b>	<b>PCM 09 Control module - Catalyst System (Exhaust Manifolds) - Pre &amp; Post Oxygen sensors</b> This system provides excellent performance while producing Super Ultra-Low emissions levels.
<b>Proven V8 Durability</b>	GM cast iron base engine with long intake runner manifold for better acceleration and handling heavy loads.
<b>Multi-Port Fuel Injection</b>	<b>Precisely outlines the exact amount of fuel.</b> Easy starting, regardless of temperature with smooth, stable idling and instant throttle response. Increased fuel efficiency. Reduced cost of operation.
<b>Gen III Cool Fuel Module</b>	Prevents fuel overheating & vapor lock for added reliability.
<b>SmartCraft</b>	Delivers information regarding key engine functions from fuel usage, RPM & engine guardian.
<b>65 Amp Alternator</b>	Provides plenty of power for onboard electronics.
<b>Easy Water Drain System</b>	Extends boating season and user friendly
<b>EDP</b>	<b>(Electro-Deposition Paint Coating)</b> Featured on exhaust manifolds, risers & elbows to resist temperature and corrosion for long life.

## AVAILABLE DRIVES

**71 C, ZF 45 C, Walter V-Drive**

**Exclusive Transmission Guardian** monitors temperature & clutch pack pressure and protects transmission from damage due to overheating or clutch slippage.

# SCORPION 350 DTS ECT **Tow Sports**

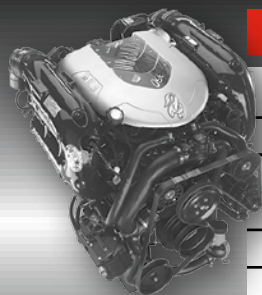

## SPECIFICATIONS

HP/kW	330 / 254
Max RPM (WOT)	4800 - 5200
Cylinders	V 8
Displacement (CID/L)	350 / 5.7
Bore X Stroke (in/mm)	4.00 x 3.48 / 101 x 88
Compression Ratio	9.4:1
Fuel/Ethanol Tolerance	87 Octane / up to 10% Ethanol
Engine Control System	PCM 09 w/SmartCraft CAN Capability, OBD-M Diagnostics, & O2 Sensors
Fuel Delivery System	Gen III Cool Fuel
Fuel Injection System	Multi-point Electronic Fuel Injection (MPI)
Induction System	Tunnel Ram w/Plenum
Ignition System	Crank Fired High Voltage Switch w/Knock Control
Charging (Amp/Watt)	65 / 917 Alternator
Water Drain System	Three-Point Manual, Optional Air Actuated
Exhaust System	Iron Manifold
Emission Control	Standard
Cooling System	Thermostatically Controlled, Raw Water, Brass Seawater Pump
Accessory Drive System	Serpentine Belt
Recommended Oil	Mercury MerCruiser Full Synthetic 20W-40W, NMMA FCW
Engine Guardian System	Low oil pressure, high coolant temperature, low seawater pressure, low voltage, over-rev control, knock control
Dimensions (LxWxH) in	43 x 30 x 21
Dimensions (LxWxH) mm	1092 x 740 x 533
Weight w/Velvet Drive (lbs/kg)	821 / 373
Full Closed Cooling System	N/A
Digital Throttle & Shift	Standard



SmartCraft Integrated Marine Technology maximizes performance and delivers a greater sense of security with innovative features.



Digital Throttle & Shift utilizes cable-less operation which eliminates helm maintenance and gives instant throttle response.

# Tow Sports **SCORPION 350 DTS ECT**

## KEY ATTRIBUTES

<b>MerCruiser's ECT Technology</b>	<b>PCM 09 Control module - Catalyst System (Exhaust Manifolds) - Pre &amp; Post Oxygen sensors</b> This system provides excellent performance while producing Super Ultra-Low emissions levels.
<b>Proven V8 Durability</b>	GM cast iron base engine with long intake runner manifold for better acceleration and handling heavy loads.
<b>Multi-Port Fuel Injection</b>	<b>Precisely outlines the exact amount of fuel.</b> Easy starting, regardless of temperature with smooth, stable idling and instant throttle response. Increased fuel efficiency. Reduced cost of operation.
<b>Gen III Cool Fuel Module</b>	Prevents fuel overheating & vapor lock for added reliability.
<b>DTS System Digital Throttle &amp; Shift</b>	Provides reliable, precise shifts and silky-smooth throttle control. <b>Automatic engine synchronization.</b>
<b>SmartCraft</b>	Delivers information regarding key engine functions from fuel usage, RPM & engine guardian.
<b>65 Amp Alternator</b>	Provides plenty of power for onboard electronics.
<b>Easy Water Drain System</b>	Extends boating season and user friendly
<b>EDP</b>	<b>(Electro-Deposition Paint Coating)</b> Featured on exhaust manifolds, risers & elbows to resist temperature and corrosion for long life.

## AVAILABLE DRIVES

**ZF 45 C Electric, Walter V-Drive**

**Exclusive Transmission Guardian** monitors temperature & clutch pack pressure and protects transmission from damage due to overheating or clutch slippage.



# STERNDRIVES

## MERCURY RACING ENGINES

**525 EFI** —

**600 SCi** —

**662 SCi** —

**700 SCi** —

**850 SCi** —

**1100** —

**1350** —

## MERCURY RACING DRIVES

**Bravo One XR** —

**Bravo One XR Sport Master** —

**Bravo Three XR** —

**Dry-Sump NXT<sup>1</sup>** —

**Dry-Sump Six** —

**Dry-Sump M8** —

# 525 EFI

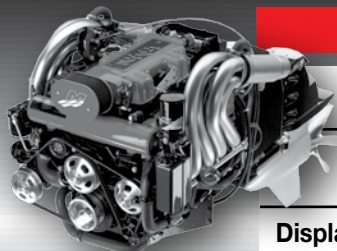

SmartCraft Integrated Marine Technology maximizes performance and delivers a greater sense of security with innovative features.



Backed by the industry's only three year limited corrosion failure warranty. Bravo Packages only.

Visit [mercuryracing.com](http://mercuryracing.com) for additional information on the 525 EFI including a full array of engine and NXT<sup>1</sup> drive color options.

## SPECIFICATIONS

<b>Horsepower</b>	<b>525 (410 kW)</b>
<b>Full Throttle RPM Range</b>	<b>4800-5200</b>
<b>Displacement Liter/CID</b>	<b>8.2/502</b>
<b>Bore (in/mm)</b>	<b>4.47/113</b>
<b>Stroke (in/mm)</b>	<b>4.00/102</b>
<b>Compression Ratio</b>	<b>8.75:1</b>
<b>Cylinders</b>	<b>V-8</b>
<b>Alternator (amp/watt)</b>	<b>90/1269</b>
<b>Controller</b>	<b>PCM Distributorless</b>
<b>Fuel System</b>	<b>MPI</b>
<b>Fuel Requirements</b>	<b>87 Posted Octane (R+M) /2 (91 RON) Global</b>
<b>Transmission*</b>	<b>Mercury Racing Dry-Sump w/NXT<sup>1</sup> or NXT<sup>1</sup> SSM</b>
<b>Drive Unit*</b>	<b>Bravo One XR,** Bravo One XR Sport Master (Std. &amp; Short),** Bravo Three XR, NXT<sup>1</sup> or NXT<sup>1</sup> SSM*</b>
<b>Gear Ratio</b>	<b>Bravo One XR, Bravo One XR Sport Master (Std. &amp; Short), 1.35:1, 1.50:1, Bravo Three XR, 1.65:1, 1.81:1 or 2.00:1, NXT<sup>1</sup>, 1.61:1, 1.50:1, 1.35:1, 1.24:1 or 1.51:1 or NXT<sup>1</sup> SSM*</b>
<b>Length (in/mm)</b>	<b>39.5/1003 (Transom Mount to Front of Engine)</b>
<b>Width (in/mm)</b>	<b>34/864</b>
<b>Height (in/mm)</b>	<b>24/610</b>
<b>Weight (lbs/kg)</b>	<b>1201/545</b>
<b>Warranty</b>	<b>1-Year Limited for Recreational Boating</b>

## KEY ATTRIBUTES

### ✓ **CNC-Machined, 502CID (8.2L)**

Cylinder block is equipped with heavy-duty connecting rods and forged aluminum pistons. *Maximum strength and durability.*

### ✓ **Mercury PCM**

Microprocessor optimizes fuel control for each cylinder independently. *Enhances engine running quality and performance.*

### ✓ **Closed Cooling System**

Factory installed system features five year coolant for reduced maintenance and increased corrosion protection. *More on-water time than ever before.*

### ✓ **90 amp Alternator**

Ensures you'll always have plenty of charging power on board. *Use all your accessories without worry.*

### ✓ **NXT<sup>1</sup>/NXT<sup>1</sup> SSM Drive Options**

Efficient transfer of raw, race-proven power to the water. *Extreme long term durability.*

## RECOMMENDED PROPS BY DRIVE

<b>Bravo One<sup>®</sup> XR</b>	Bravo I <sup>®</sup> Sterndrive / Maximus <sup>®</sup>
<b>Bravo Three<sup>®</sup> XR</b>	Bravo Three <sup>®</sup> XR
<b>NXT<sup>1</sup></b>	Maximus / Pro Finished <sup>®</sup> 5-Blade CNC Cleaver
<b>NXT<sup>1</sup> SSM</b>	Pro Finished <sup>®</sup> 5-Blade CNC Cleaver
<b>Hi-Performance Prop Applications</b>	Contact Mercury Racing Performance Propeller Manager at <b>920-924-2037</b> regarding propeller applications and performance.

# 600 sci

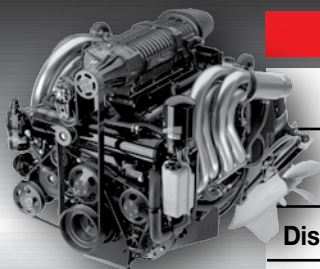

<b>SPECIFICATIONS</b>	
<b>Horsepower</b>	600 (447 kW)
<b>Full Throttle RPM Range</b>	4800-5200
<b>Displacement Liter/CID</b>	8.2/502
<b>Bore (in/mm)</b>	4.47/113
<b>Stroke (in/mm)</b>	4.00/102
<b>Compression Ratio</b>	7.50:1
<b>Cylinders</b>	V-8
<b>Alternator (amp/watt)</b>	90/1269
<b>Controller</b>	PCM Distributorless
<b>Fuel System</b>	Sequential Fuel Injection
<b>Fuel Requirements</b>	87 Posted Octane (R+M) /2 (91 RON) Global
<b>Transmission*</b>	Mercury Racing Dry-Sump w/NXT <sup>1</sup> or NXT <sup>1</sup> SSM*
<b>Drive Unit*</b>	Bravo One XR,** Bravo One XR Sport Master (Std. & Short),** NXT <sup>1</sup> or **NXT <sup>1</sup> SSM*
<b>Gear Ratio</b>	Bravo One XR, Bravo One XR Sport Master (Std. & Short), 1.35:1, 1.50:1; NXT <sup>1</sup> , 1.65:1, 1.50:1, 1.35:1, 1.24:1, 1.15:1 or NXT <sup>1</sup> SSM*
<b>Length (in/mm)</b>	35.7/907 (Transom Mount to Front of Engine)
<b>Width (in/mm)</b>	33/838
<b>Height (in/mm)</b>	27.2/691
<b>Weight (lbs/kg)</b>	1267/575
<b>Warranty</b>	1-Year Limited for Recreational Boating



SmartCraft Integrated Marine Technology maximizes performance and delivers a greater sense of security with innovative features.



Backed by the industry's only three year limited corrosion failure warranty. Bravo Packages only.

Visit [mercuryracing.com](http://mercuryracing.com) for additional information on the 600 SCI including a full array of engine and NXT<sup>1</sup> drive color options.

## KEY ATTRIBUTES

### ✓ **Meets Emission Requirements**

As set forth in the EU RCD emissions requirements - CE marked.  
*More freedom to roam.*

### ✓ **Active Torque Management**

Via an electronic boost bypass control valve ensures consistent 600 horsepower. *Enhances performance quality.*

### ✓ **Advanced Closed Cooling System**

Factory installed system features five year coolant for reduced maintenance and increased corrosion protection.  
*More on-water time than ever before.*

### ✓ **NXT<sup>1</sup> Drive Option**

Combines the best features of the Bravo One XR and dry-sump Six drive. *Extreme long term durability.*

### ✓ **90 amp Alternator**

Ensures you'll always have plenty of charging power on board.  
*Use all your accessories without worry.*

### ✓ **VesselView Race Edition**

Custom interactive software specifically designed to maximize boat performance and track vital information for up to three motors.

## RECOMMENDED PROPS BY DRIVE

<b>Bravo One<sup>®</sup> XR</b>	Bravo I <sup>®</sup> Sterndrive / Maximus <sup>®</sup>
<b>NXT<sup>1</sup></b>	Maximus / Pro Finished <sup>®</sup> 5-Blade CNC Cleaver
<b>NXT<sup>1</sup> SSM</b>	Pro Finished <sup>®</sup> 5-Blade CNC Cleaver
<b>Hi-Performance Prop Applications</b>	Contact Mercury Racing Performance Propeller Manager at <b>920-924-2037</b> regarding propeller applications and performance.

# 662 sci

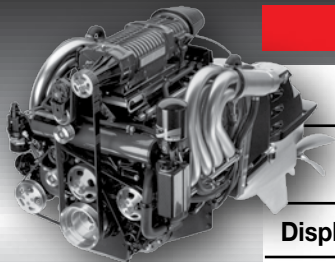

SmartCraft Integrated Marine Technology maximizes performance and delivers a greater sense of security with innovative features.

Visit [mercuryracing.com](http://mercuryracing.com) for additional information on the 662 Sci including a full array of engine and drive color options.

## SPECIFICATIONS

<b>Horsepower</b>	662 (494 kW)
<b>Full Throttle RPM Range</b>	4800-5200
<b>Displacement Liter/CID</b>	8.2/502
<b>Bore (in/mm)</b>	4.47/113
<b>Stroke (in/mm)</b>	4.00/102
<b>Compression Ratio</b>	7.50:1
<b>Cylinders</b>	V-8
<b>Alternator (amp/watt)</b>	90/1269
<b>Controller</b>	PCM Distributorless
<b>Fuel System</b>	Sequential Fuel Injection
<b>Fuel Requirements</b>	89 Posted Octane (R+M)/2 (95 RON) Global
<b>Transmission</b>	Mercury Racing Dry-Sump
<b>Drive Unit</b>	NXT <sup>1</sup> or NXT <sup>1</sup> SSM*
<b>Gear Ratio</b>	NXT <sup>1</sup> , 1.61:1, 1.50:1, 1.35:1, 1.24:1, 1.15:1 or NXT <sup>1</sup> SSM*
<b>Length (in/mm)</b>	35.7/907 (Transom Mount to Front of Engine)
<b>Width (in/mm)</b>	33/838
<b>Height (in/mm)</b>	27.7/709
<b>Weight (lbs/kg)</b>	1548/702
<b>Warranty</b>	1-Year Limited for Recreational Boating

## KEY ATTRIBUTES

✓ **89 Posted Pump Octane**

(R+M)/2 or (RON) Global fuel calibration offers greater access to on-water fuel. *More room to roam.*

✓ **Meets Emission Requirements**

As set forth in the EU RCD emissions requirements - CE marked. *More freedom to roam.*

✓ **Mercury PCM**

Propulsion Control Module microprocessor optimizes fuel control for each cylinder independently.

*Enhances engine running quality and performance.*

✓ **SmartCraft**

SmartCraft Integrated Marine Technology maximizes performance and delivers a greater sense of security with innovative features.

*With Engine Guardian protection.*

✓ **90 amp Alternator**

Ensures you'll always have plenty of charging power on board.

*Use all your accessories without worry.*

## ADDITIONAL FEATURES / BENEFITS

**Recommended Props**

Pro Finished® **5-Blade** CNC Cleaver  
Pro Finished® **6-Blade** CNC Cleaver

**Hi-Performance Prop Applications**

Contact Mercury Racing Performance Propeller Manager at **920-924-2037** regarding propeller applications and performance.

**VesselView Race Edition**

Custom interactive software specifically designed to help maximize boat performance and track vital information in real-time for up to three motors.

# 700 sci

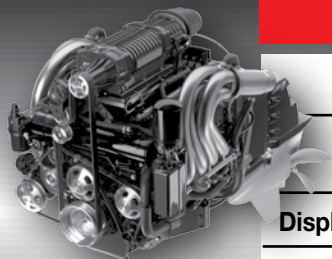

SmartCraft Integrated Marine Technology maximizes performance and delivers a greater sense of security with innovative features.

Visit [mercuryracing.com](http://mercuryracing.com) for additional information on the 700 SCI including a full array of engine and drive color options.

## SPECIFICATIONS

<b>Horsepower</b>	<b>700 (522 kW)</b>
<b>Full Throttle RPM Range</b>	<b>4800-5200</b>
<b>Displacement Liter/CID</b>	<b>8.2/502</b>
<b>Bore (in/mm)</b>	<b>4.47/113</b>
<b>Stroke (in/mm)</b>	<b>4.00/102</b>
<b>Compression Ratio</b>	<b>7.50:1</b>
<b>Cylinders</b>	<b>V-8</b>
<b>Alternator (amp/watt)</b>	<b>90/1269</b>
<b>Controller</b>	<b>PCM Distributorless</b>
<b>Fuel System</b>	<b>Sequential Fuel Injection</b>
<b>Fuel Requirements</b>	<b>89 Posted Octane (R+M) /2 (95 RON) Global</b>
<b>Transmission</b>	<b>Mercury Racing Dry-Sump</b>
<b>Drive Unit</b>	<b>NXT<sup>1</sup> or NXT<sup>1</sup> SSM</b>
<b>Gear Ratio</b>	<b>NXT<sup>1</sup>, 1.61:1, 1.50:1, 1.35:1, 1.24:1, or 1.15:1 or NXT<sup>1</sup> SSM*</b>
<b>Length (in/mm)</b>	<b>35.7/907</b> (Transom Mount to Front of Engine)
<b>Width (in/mm)</b>	<b>33/838</b>
<b>Height (in/mm)</b>	<b>27.7/709</b>
<b>Weight (lbs/kg)</b>	<b>1548/702</b>
<b>Warranty</b>	<b>1-Year Limited for Recreational Boating</b>

\*Application Dependent: Contact Mercury Racing for additional information

## KEY ATTRIBUTES

### ✓ **89 Posted Pump Octane**

(R+M)/2 or (RON) Global fuel calibration offers greater access to on-water fuel. **More room to roam.**

### ✓ **CNC-Machined, 502CID (8.2L)**

Cylinder block is equipped with heavy-duty connecting rods and forged aluminum pistons. **Maximum strength and durability.**

### ✓ **Custom Camshaft Design**

Combined with a taller intercooler, increased supercharger boost, and updated fuel calibration.

**Results in a consistent 700 crankshaft horsepower.**

### ✓ **Sweeper Headers**

Feature a new alloy for enhanced saltwater corrosion resistance and durability. **Longer engine life.**

### ✓ **90 amp Alternator**

Ensures you'll always have plenty of charging power on board.

**Use all your accessories without worry.**

## ADDITIONAL FEATURES / BENEFITS

### **Recommended Props**

Pro Finished® **5-Blade** CNC Cleaver  
Pro Finished® **6-Blade** CNC Cleaver

### **Hi-Performance Prop Applications**

Contact Mercury Racing Performance Propeller Manager at **920-924-2037** regarding propeller applications and performance.

### **VesselView Race Edition**

Custom interactive software specifically designed to help maximize boat performance and track vital information in real-time for up to three motors.

# 850 sci

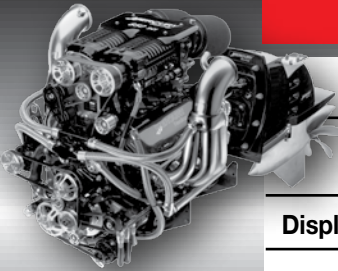

SmartCraft Integrated Marine Technology maximizes performance and delivers a greater sense of security with innovative features.

Visit [mercuryracing.com](http://mercuryracing.com) for additional information on the 850 SCi including a full array of engine and drive color options.

## SPECIFICATIONS

<b>Horsepower</b>	<b>850 (634 kW)</b>
<b>Full Throttle RPM Range</b>	<b>5500-5800</b>
<b>Displacement Liter/CID</b>	<b>9.1/557</b>
<b>Bore (in/mm)</b>	<b>4.50/114</b>
<b>Stroke (in/mm)</b>	<b>4.375/111</b>
<b>Compression Ratio</b>	<b>8.00:1</b>
<b>Cylinders</b>	<b>V-8</b>
<b>Alternator (amp/watt)</b>	<b>90/1269</b>
<b>Controller</b>	<b>PCM Distributorless</b>
<b>Fuel System</b>	<b>Sequential Fuel Injection</b>
<b>Fuel Requirements</b>	<b>89 Posted Octane (R+M) /2 (95 RON) Global</b>
<b>Transmission</b>	<b>BAM Cyborg</b>
<b>Drive Unit</b>	<b>Dry-Sump Six</b>
<b>Gear Ratio</b>	<b>Application Dependent: Contact Mercury Racing for additional information</b>
<b>Length (in/mm)</b>	<b>55/1397</b>
<b>Width (in/mm)</b>	<b>40/1016 (w/ CMI Exhaust System)</b>
<b>Height (in/mm)</b>	<b>30/762 (w/ CMI Exhaust System)</b>
<b>Weight (lbs/kg)</b>	<b>1720/782</b>
<b>Warranty</b>	<b>180-Day Limited for Recreational Boating</b>

## KEY ATTRIBUTES

### ✓ **89 Posted Pump Octane**

(R+M)/2 or (RON) Global fuel calibration offers greater access to on-water fuel. *More room to roam.*

### ✓ **Cast Iron Cylinder Block**

557-cubic-inch tall deck cast iron cylinder block features five main bearings with stud fastened steel main bearing caps. *Durability.*

### ✓ **Mercury PCM**

Microprocessor optimizes fuel, spark timing, and knock control for each cylinder independently.

*Enhances engine running-quality and performance.*

### ✓ **Dry-Sump Lubrication**

An innovation that reduces friction and adds horsepower for improved overall boat performance. *Enhanced power and efficiency.*

### ✓ **90 amp Alternator**

Ensures you'll always have plenty of charging power on board.

*Use all your accessories without worry.*

## ADDITIONAL FEATURES / BENEFITS

### **Recommended Props**

Pro Finished® **5-Blade** CNC Cleaver  
Pro Finished® **6-Blade** CNC Cleaver

### **Hi-Performance Prop Applications**

Contact Mercury Racing Performance Propeller Manager at **920-924-2037** regarding propeller applications and performance.

### **VesselView Race Edition**

Custom interactive software specifically designed to help maximize boat performance and track vital information in real-time for up to three motors.

# 1100

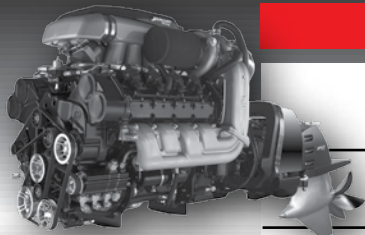

SmartCraft Integrated Marine Technology maximizes performance and delivers a greater sense of security with innovative features.

Visit [mercuryracing.com](http://mercuryracing.com) for additional information on the 1100 including a full array of engine and drive color options.

## SPECIFICATIONS

Horsepower	1100 (820 kW)
Full Throttle RPM Range	6000-6500
Displacement Liter/CID	9.0/552
Bore (in/mm)	4.57/116
Stroke (in/mm)	4.21/107
Compression Ratio	7.8:1
Cylinders	V-8
Alternator (amp/watt)	105/1481
Controller	PCM Distributorless
Fuel System	Sequential Fuel Injection
Fuel Requirements	89 Octane Minimum (R + M)/2, (95 RON) Global Calibration
Transmission	Mercury Racing Dry-Sump Hydraulic
Drive Unit	Dry-Sump NXT1 SSM, M8
Gear Ratio	Application Dependent: Contact Mercury Racing for additional information
Length (in/mm)	26.69/678 (from back of block)
Width (in/mm)	34/864
Height (in/mm)	29/737 (from crankshaft centerline)
Weight (lbs/kg)	1720/782
Warranty	1-Year Limited for Recreational Boating

## KEY ATTRIBUTES

## 9.0 L (552 cid) - 90° DOHC V-8

### ✓ **Aluminum Block & Heads**

Designed and developed by Mercury Racing, this lightweight design provides enhanced strength and durability. **Built to last.**

### ✓ **Durable NiCom® Coating**

Aluminum cylinder bores are coated with durable NiCom® for enhanced heat transfer and durability. **Tough.**

---

## Quad cam, 4 valve (QC4v)

### ✓ **Overhead cam design**

Extends the operating rpm range.

### ✓ **Twin, Water Cooled Turbochargers**

Delivers better performance, fuel economy with reduced noise and exceptional sound quality.

**Optimizes power and torque throughout the engine operating RPM range , while improving durability.**

---

## QC4v Technology

### ✓ **Electronic Turbo-Compressor**

Delivers a broad “mesa shaped” torque curve under all operating conditions. **Power to perform.**

### ✓ **Integral Exhaust System**

Design features pulse separated exhaust tuning to improve low RPM turbocharger response. **Better performance at low RPM.**

### ✓ **Closed Cooling**

Enhances corrosion resistance and improves engine cooling. **Lasts.**



## KEY ATTRIBUTES

# Advanced Electronics

### ✓ **Propulsion Control Module (PCM)**

- Microprocessor w/Mercury Racing software
- Sequential fuel MAP and spark advance

*Delivers excellent fuel economy along with superior running quality*

### ✓ **SmartCraft (DTS) Digital Throttle & Shift**

- Single-turn “SmartStart”
- Automatic throttle synchronization
- “Shadow mode” (where two levers control three or four engines)

*Provides precision operation with luxury-car-like drivability.*

### ✓ **Engine Guardian**

Real-time, self-protection engine fault diagnostics and messaging.

*Protects your investment.*

### ✓ **105 Amp Charging System**

Get **50%** more output compared to competitive models.

*Ample power supply for today’s advanced marine electronics.*



## KEY ATTRIBUTES

## Propulsion System:

✓ **Unique hydraulic transmission to handle the 1100's high torque.**

- **35%** more friction surface
- Improved design and materials. **Built to Last.**

✓ **Dry-Sump NXT<sup>1</sup> SSM with gear ratios from 1.15:1 to 1.42:1.**

- Features the legendary **Six Drive Design** with the new **M Series** transom plate.
- For lighter, very fast boats. **Built to Perform.**

✓ **Dry-sump M8 drive with 1.30:1, 1.40:1, 1.53:1 or 1.69:1 gear ratio**

- Surface piercing gearcase, packed with heavy-duty components, is designed specifically to handle the **1100's higher torque** along with a slim gear housing shape for hydrodynamic efficiency.
- Built to Keep going.**

✓ **Pro Finish 5 & 6-blade CNC sterndrive propellers**

- Designed with stamina for the **1100's massive torque** and surface piercing impact
- The props are backed with a **1-year factory warranty** when used on Mercury Racing engine packages

**Hi-Performance  
Prop Applications**

Contact Mercury Racing Performance Propeller Manager at **920-924-2037** regarding propeller applications and performance.

# 1350

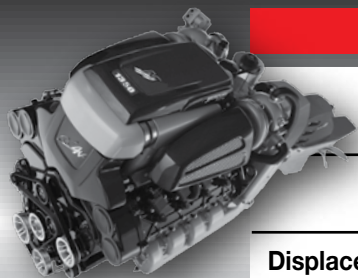

SmartCraft Integrated Marine Technology maximizes performance and delivers a greater sense of security with innovative features.

Visit [mercuryracing.com](http://mercuryracing.com) for additional information on the 1350 including a full array of engine and drive color options.

## SPECIFICATIONS

<b>Horsepower</b>	<b>1350 (1006 kW)</b>
<b>Full Throttle RPM Range</b>	<b>6000-6500</b>
<b>Displacement Liter/CID</b>	<b>9.0/552</b>
<b>Bore (in/mm)</b>	<b>4.57/116</b>
<b>Stroke (in/mm)</b>	<b>4.21/107</b>
<b>Compression Ratio</b>	<b>7.8:1</b>
<b>Cylinders</b>	<b>V-8</b>
<b>Alternator (amp/watt)</b>	<b>105/1481</b>
<b>Controller</b>	<b>PCM Distributorless</b>
<b>Fuel System</b>	<b>Sequential Fuel Injection</b>
<b>Fuel Requirements</b>	<b>91 Posted Octane (R+M)/2, (98 RON) Global</b>
<b>Transmission</b>	<b>Mercury Racing Dry-Sump Hydraulic</b>
<b>Drive Unit</b>	<b>Dry-Sump M8</b>
<b>Gear Ratio</b>	<b>Application Dependent: Contact Mercury Racing for additional information</b>
<b>Length (in/mm)</b>	<b>26.69/678 (from back of block)</b>
<b>Width (in/mm)</b>	<b>34/864</b>
<b>Height (in/mm)</b>	<b>29/737 (from crankshaft centerline)</b>
<b>Weight (lbs/kg)</b>	<b>1720/782</b>
<b>Warranty</b>	<b>1-Year Limited for Recreational Boating</b>

## KEY ATTRIBUTES

## 9.0 L (552 cid) - 90° DOHC V-8

### ✓ **Aluminum Block & Heads**

Designed and developed by Mercury Racing, this lightweight design provides enhanced strength and durability. **Built to last.**

### ✓ **Durable NiCom® Coating**

Aluminum cylinder bores are coated with durable NiCom® for enhanced heat transfer and durability. **Tough.**

---

## Quad cam, 4 valve (QC4v)

### ✓ **Overhead cam design**

Extends the operating rpm range.

### ✓ **Twin, Water Cooled Turbochargers**

Delivers better performance, fuel economy with reduced noise and exceptional sound quality.

**Optimizes power and torque throughout the engine operating RPM range, while improving durability.**

---

## QC4v Technology

### ✓ **Electronic Turbo-Compressor**

Delivers a broad “mesa shaped” torque curve under all operating conditions. **Power to perform.**

### ✓ **Integral Exhaust System**

Design features pulse separated exhaust tuning to improve low RPM turbocharger response. **Better performance at low RPM.**

### ✓ **Closed Cooling**

Enhances corrosion resistance and improves engine cooling. **Lasts.**

# 1350



## KEY ATTRIBUTES

# Advanced Electronics

### ✓ **Propulsion Control Module (PCM)**

- Microprocessor w/Mercury Racing software.
- Sequential fuel MAP and spark advance.

*Delivers excellent fuel economy along with superior running quality*

### ✓ **SmartCraft (DTS) Digital Throttle & Shift**

- Single-turn “SmartStart”.
- Automatic throttle synchronization
- “Shadow mode” (where two levers control three or four engines)

*Provides precision operation with luxury-car-like drivability.*

### ✓ **Engine Guardian**

Real-time, self-protection engine fault diagnostics and messaging.

*Protects your investment.*

### ✓ **105 Amp Charging System**

Get **50%** more output compared to competitive models.

*Ample power supply for today’s advanced marine electronics.*



## KEY ATTRIBUTES

## Propulsion System:

✓ **Unique hydraulic transmission to handle the 1350's high torque.**

- **35%** more friction surface.
- Improved design and materials. **Built to Last.**

✓ **M8 Drive combines the best features of the dry-sump NXT<sup>1</sup> and Six Drives**

- All new **surface piercing gearcase**, packed with heavy-duty components. **Endurance.**
- Delivers **35%** more capacity than the legendary Six Drive.
- Innovative design with a **1.30:1** or **1.40:1** gear ratio **splits the torque load** for a high power capacity while maintaining a slim gear housing shape for **hydrodynamic efficiency**.

✓ **Pro Finish 5 & 6-blade CNC sterndrive propellers**

- Designed with stamina for the **1350's massive torque** and surface piercing impact.
- The props are backed with a **1-year factory warranty** when used on Mercury Racing engine packages.

### Hi-Performance Prop Applications

Contact Mercury Racing Performance Propeller Manager at **920-924-2037** regarding propeller applications and performance.

# Bravo One XR Drive

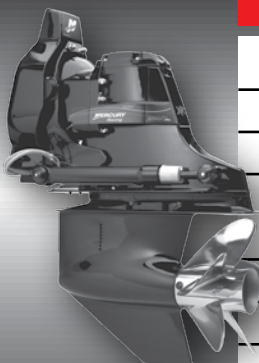

## SPECIFICATIONS

Max. Power Cap. (hp/kW)	600/447
Lower Unit Design	Performance Torpedo
Water Inlet Location	DWP - Torpedo and Strut
Clutch Type	High-Strength Smooth Shift Cone Clutch with F-N-R
Available Gear Ratios	1.35, 1.50:1
Counter Rotation	Standard
Upper Unit Gear Set	Precision shimmed assembly w/net forged steel "straight bevel" gears, reinforced ribbed top cap, heavy-duty caged roller bearing
Lower Unit Gear Set	Precision shimmed assembly w/net forged steel "straight bevel" gear
Propshaft Material	Heat treated stainless steel / Larger 1.25" Diameter
Propeller Hub Type	Solid Hub
Exhaust Outlet	Low restriction through transom
Recommended Lube	Mercury High-Performance Gear Lube
Monitoring System	Drive lube monitor w/audio warning or Engine Guardian
Corrosion Protection	MercFusion paint System, anodes & MerCathode kit
Anode Type	Ultra-pure aluminum anodes or magnesium anode kit
Speedometer Pick-up	Integrated into lower housing
Steering System	ITS Option
Power Trim System	Twin-cylinder hydraulic featuring Power Trim XD kick-up return
Trim Limit Switch	Adjustable limit analog or digital
Drive Weight (lbs/kg)	130/59



Backed by the industry's only three year limited corrosion failure warranty.

# Drive **Bravo One XR**

**Bravo One XR** - Single-propeller models for single or multiple engine installations with the capability of speed **over 90 MPH.**

## KEY ATTRIBUTES

### Patented Cone Clutch

✓ High-Strength Smooth Shift with **F-N-R**  
*Less shifting effort with positive engagement. Comfort.*

### Heavy Duty PermaLube® U-Joint

### Stronger Driveshaft

✓ With heavy duty bearing. *Reliability.*

### Net Forged Straight Bevel Gears

✓ Precision Shimmed. *Superior Durability.*

### Reinforced Top Cap

✓ Ribbed for cooling to support bearings under high load. *Reliability.*

### Heavy Duty Forged Gears

✓ Precision shimmed net forged steel "Straight Bevel" gears. *Best strength & durability.*

### Billet Anodized Bearing Carrier

✓ Stronger with corrosion protection. *Durability.*

### 1.25" Larger Propshaft *Reliability.*



## ADDITIONAL FEATURES / BENEFITS

### Transom Plate Assembly

Features a heavy-duty gimbal assembly design and components for long term durability.

### Stronger PermaLube® U-Joint

Transmits monster torque loads. Provides exceptional performance with virtually no maintenance required for reduced cost of operation.

### MerCathode

An active cathodic corrosion protection system.

# Bravo One XR Sport Master Drive

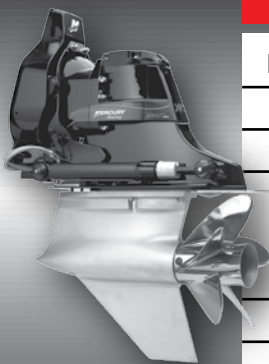

## SPECIFICATIONS

Max. Power Cap. (hp/kW)	600/447
Lower Unit Design	Performance Torpedo
Water Inlet Location	DWP - Torpedo and Strut
Clutch Type	High-Strength Smooth Shift Cone Clutch with F-N-R
Available Gear Ratios	1.35, 1.50:1
Counter Rotation	Standard
Upper Unit Gear Set	Precision shimmed assembly w/net forged steel "straight bevel" gears, reinforced ribbed top cap, heavy-duty caged roller bearing
Lower Unit Gear Set	Precision shimmed assembly w/net forged steel "straight bevel" gear
Propshaft Material	Heat treated stainless steel / Larger 1.25" Diameter
Propeller Hub Type	Solid Hub
Exhaust Outlet	Low restriction through transom
Recommended Lube	Mercury High-Performance Gear Lube
Monitoring System	Drive lube monitor w/audio warning or Engine Guardian
Corrosion Protection	MercFusion paint System, anodes & MerCathode kit
Anode Type	Ultra-pure aluminum anodes or magnesium anode kit
Speedometer Pick-up	Integrated into lower housing
Steering System	ITS Option
Power Trim System	Twin-cylinder hydraulic featuring Power Trim XD kick-up return
Trim Limit Switch	Adjustable limit analog or digital
Drive Weight (lbs/kg)	130/59



Backed by the industry's only three year limited corrosion failure warranty.

# Drive **Bravo One XR** Sport Master

**Bravo One XR Sport Master** features a crescent design torpedo gearcase with front mounted low water pick-ups that allows for higher X-Dimensions, thus reducing drag and improving performance.

## KEY ATTRIBUTES

### Patented Cone Clutch

- ✓ High-Strength Smooth Shift with **F-N-R**  
*Less shifting effort with positive engagement. Comfort.*

### Heavy Duty PermaLube® U-Joint

- ✓ Transmits monster torque loads.  
*Providing exceptional Performance.*

### Four Slot Low Water Pickup

- ✓ Provides the best compromise of engine cooling while reducing debris ingestion **Reliability.**



### Reinforced Top Cap

- ✓ Ribbed for cooling to support bearings under high load.  
**Reliability.**

### Heavy Duty Forged Gears

- ✓ Precision shimmed net forged steel "Straight Bevel" gears. **Best strength & durability.**

### 1.25" Larger Propshaft

**Reliability.**

### Longer Skeg

- ✓ Large rudder surface area for steering response.  
**Improves boat handling.**

### Net Forged Straight Bevel Gears

- ✓ Precision Shimmed Assembly Forged Steel Gears with Anodized Billet Bearing Carrier. **Superior Durability.**

### **A Robust design**

- ✓ **To handle high torque (Durability).**
- ✓ **Built to push big boats with authority.**
- ✓ **While maintaining "best-in-class" shifting.**

# Bravo Three XR Drive

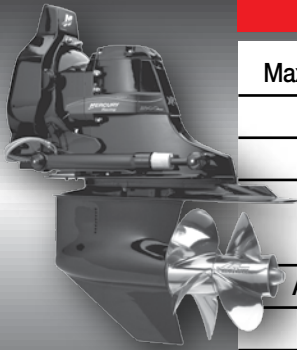

## SPECIFICATIONS

Max. Power Cap. (hp/kW)	600/447
Lower Unit Design	Performance Torpedo
Water Inlet Location	DWP - Torpedo and Strut
Clutch Type	High-Strength Smooth Shift Cone Clutch with F-N-R
Available Gear Ratios	1.65, 1.81:1, 2.00:1
Counter Rotation	Standard
Upper Unit Gear Set	Precision shimmed assembly w/net forged steel "straight bevel" gears, reinforced ribbed top cap, heavy-duty caged roller bearing
Lower Unit Gear Set	Precision shimmed assembly w/net forged steel "straight bevel" gear
Propshaft Material	Heat treated stainless steel / Larger 1.25" Diameter
Propeller Hub Type	Solid Hub
Exhaust Outlet	Low restriction through transom
Recommended Lube	Mercury High-Performance Gear Lube
Monitoring System	Drive lube monitor w/audio warning or Engine Guardian
Corrosion Protection	MercFusion paint System, anodes & MerCathode kit
Anode Type	Ultra-pure aluminum anodes or magnesium anode kit
Speedometer Pick-up	Integrated into lower housing
Steering System	ITS Option
Power Trim System	Twin-cylinder hydraulic featuring Power Trim XD kick-up return
Trim Limit Switch	Adjustable limit analog or digital
Drive Weight (lbs/kg)	130/59



Backed by the industry's only three year limited corrosion failure warranty.

# Drive **Bravo Three XR**

**Bravo Three XR** Dual counter-rotating propeller models for single or twin installations.

## KEY ATTRIBUTES

### Patented Cone Clutch

- ✓ High-Strength Smooth Shift with **F-N-R**

*Less shifting effort with positive engagement. Comfort.*

### Heavy Duty PermaLube® U-Joint

### Stronger Driveshaft

- ✓ With heavy duty bearing. **Reliability.**

### Net Forged Straight Bevel Gears

- ✓ Precision Shimmed. **Superior Durability.**

### Reinforced Top Cap

- ✓ Ribbed for cooling to support bearings under high load.

**Reliability.**

### Heavy Duty Forged Gears

- ✓ Precision shimmed net forged steel "Straight Bevel" gears.

**Best strength & durability.**

### Extended Anti-Ventilation Plate

### Billet Anodized Bearing Carrier

- ✓ Stronger with corrosion prevention. **Durability.**

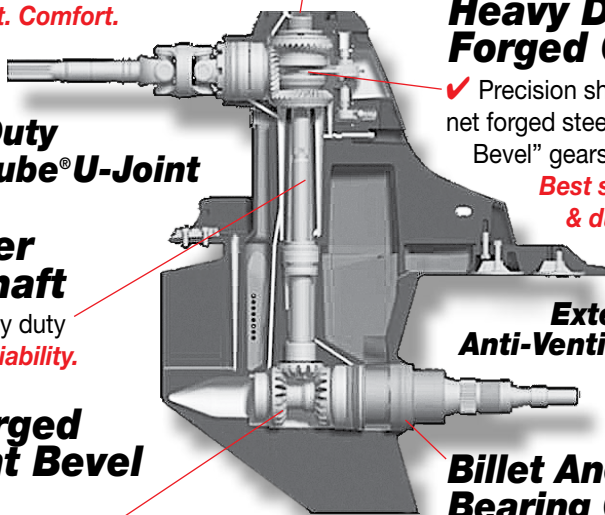

## Bravo Three XR Benefits

**Helps the boat get on plane without the tendency for the bow to rise.**

- ✓ Can see while boat is getting on plane.
- ✓ 30% Quicker acceleration.
- ✓ Better for pulling skiers or tubers .

**Allows the hull to maintain a planing attitude at a lower speeds.**

- ✓ No steering torque as compared to single prop.
- ✓ Improves hull maneuverability - comfort.
- ✓ Better efficiency for reduced cost of operation .
- ✓ No Prop blow-out in tight turns.

## SPECIFICATIONS

Max. Power Cap.	700 hp Input torque rating of 800 ft. lbs.
Lower Unit Design	Dry Sump Drive & Transmission
Max. Prop Diameter	18 inches
Available Gear Ratios	Contact Mercury Racing Performance Group
Proshaft Rotation	Left Hand or Right Hand Rotation
Drive Weight (lbs./kg.)	218 / 99

## KEY ATTRIBUTES

### Mercury Racing Transmission

- ✓ Features a compact, integrated transmission, developed by Mercury Racing.
- ✓ A durable design that can handle input torque rating of 800 ft. lbs.
- ✓ The unique through-hull location of the transmission enables easy access to remove for service without removing the entire engine.

**Compact, Efficient with Maintenance ease.**

### Forged Lower Unit Gears

- ✓ Provides greater strength
- Built for endurance.**

### Rear Mounted Water Intake

- ✓ Ensures proper cooling to engine. The design incorporates optional size pick-ups.

**Reliability with convenience.**

### Exclusive Drive Oil Pump

- ✓ While the lower drive cavity is bathed in oil, a unique propshaft driven oil pump sprays the upper drive gears for lubrication. This reduces internal friction, increasing performance.

**Increased Endurance & Performance.**

### Crescent Leading Edge Design

- ✓ For hulls capable of speeds in excess of 90 MPH boats. Maximizes efficiency and speed.
- Less drag, more speed.**

### Stainless Steel Propshaft

- ✓ And hub adapters enable both the 5-blade Maximus\* propeller and CNC machined 5-blade cleaver propellers to be used.
- Durability with more propulsion options.**

\*Limited to 525 EFI and 600 SCI applications

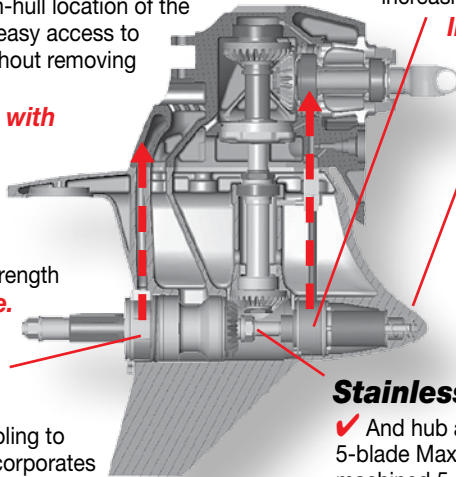

### Cambered Skag NXT<sup>1</sup>

- ✓ A drive option that helps compensate steering loads experienced with single & triple engine boats.
- User Comfort with better control & performance.**

 Cambered Skag
  Non-Cambered Skag

## KEY ATTRIBUTES

**✓ Dry Sump Lubrication**

Drive and transmission feature dry-sump lubrication.

An innovation that *reduces friction, operating temperatures and adds horsepower for improved overall boat performance. Higher Efficiency & better Performance.*

**✓ Interchangeable Water Pickups**

Mounted at the rear of the gearcase torpedo - interchangeable with available accessory pick-ups for multiple hull-type configurations and speeds. *Adapts to customer needs.*

*The water pick-up is located at the rear of the gearcase torpedo to increase the water volume flow to the engine.*

*Reliability.*

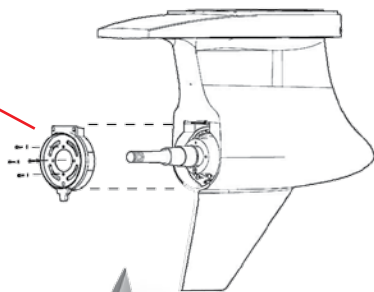
**✓ Propellers**

Mercury Racing's CNC machined cleaver propellers.

A complete line of the **Pro Finished 5-Blade** and **6-Blade CNC** models are available to fit virtually any application.

*Maximizes hull performance.*

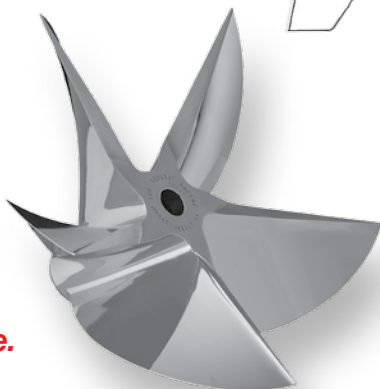
**✓ NXT<sup>1</sup> SSM Drive (Optional)**

Offers OEM boat builders and consumers the benefit of using the legendary dry-sump Six drive with the engine mounted in the same location as a Bravo drive set-up.

*Contact Mercury Racing Performance Manager for more Information.*

# Dry Sump Six Drive

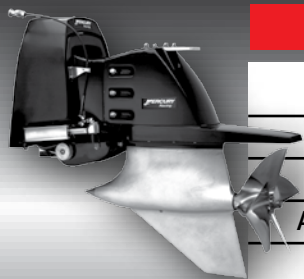

## SPECIFICATIONS

Max. Power Cap.	1200 hp Input torque rating of 1160 ft. lbs.
Lower Unit Design	Dry Sump Drive & Transmission
Max. Prop Diameter	18 inches
Available Gear Ratios	1.61:1, 1.50:1, 1.35:1, 1.24:1, 1.15:1
Proshaft Rotation	Left Hand or Right Hand Rotation
Drive Weight (lbs./kg.)	255 / 115.6

## KEY ATTRIBUTES

### Twin Pinion Gear Shaft Design

#### ✓ A time-proven Mercury Exclusive

First patented by Mercury for outboard racing back in the **1950s**, this innovative design splits the torque load for a high power capacity while maintaining a slim gear housing shape for hydrodynamic efficiency.

### 850-1200hp

✓ Input rated up to **1160** foot pounds of torque.  
**Performance.**

### Swept Back Skeg Design

✓ Improves steering response and hull maneuverability, in no matter what type of sea conditions.

**Comfort with Improved Hull Control**

### Heavy-Duty Universal Joint

✓ Along with a large driveshaft, it delivers the engine torque for top performance and added endurance. **Durability with Less Required Maintenance.**

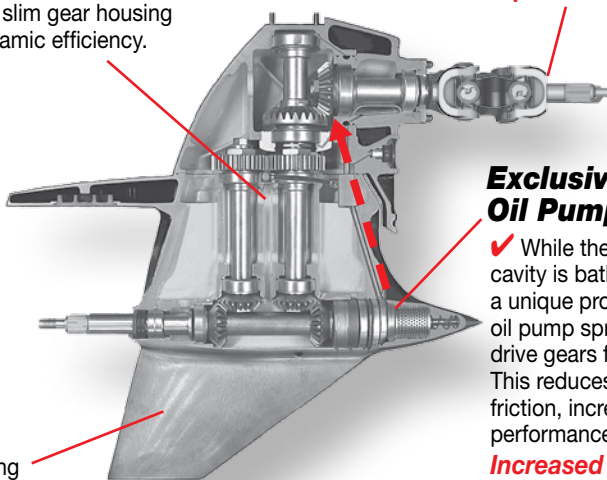

### Exclusive Drive Oil Pump

✓ While the lower drive cavity is bathed in oil, a unique propshaft driven oil pump sprays the upper drive gears for lubrication. This reduces internal friction, increasing performance.

**Increased Endurance & Performance.**

### Hydraulic Power Steering

✓ Cylinders are designed into the drive unit. This improves steering response along with strengthening the integrity of the design.

**Improves Hull Handling with Added Durability.**

## KEY ATTRIBUTES

### ✓ **Dry Sump Lubrication**

Drive and transmission feature dry-sump lubrication. An innovation that reduces friction, operating temperatures and adds horsepower for improved overall boat performance. **Higher Efficiency & better Performance.**

### ✓ **Propellers**

Mercury Racing's CNC machined cleaver propellers. A complete line of the **Pro Finished 5-Blade** and **6-Blade CNC** models are available to fit virtually any application. **Maximizes hull performance.**

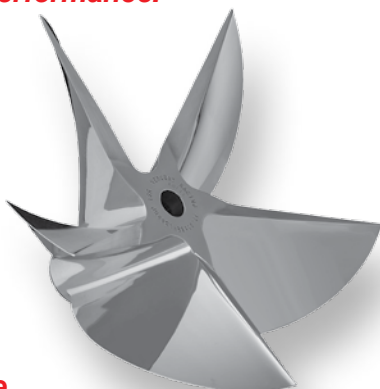

### **K-Plane® Trim Tabs**

Originally designed to endure the rigors of offshore racing, K-Planes help get boats up on plane faster and keep them level. Selected models of the legendary trim tabs have been updated for enhanced durability, corrosion resistance and SmartCraft® compatibility.

**Maximizes hull performance.**



## KEY ATTRIBUTES

- 1. Strong, corrosion resistant aluminum casting with large support ribs for enhanced durability.**
- 2. Double-acting hydraulic trim cylinders maintain position and react immediately to fingertip control from the helm.**
- 3. Heavy-duty hydraulic trim pumps are designed specifically for use with K-Planes.**
- 4. Selected models come equipped for adaptation of an electronic SmartCraft® compatible trim sender. The electronic sender enables boaters to view digital images of tab trim positions at a glance.**

# Dry Sump M8

## Drive

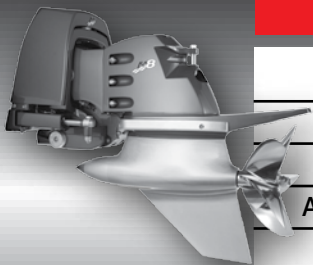

### SPECIFICATIONS

Max. Power Cap.	1350 hp Input torque rating of 1300 ft. lbs.
Lower Unit Design	Dry Sump Drive & Transmission
Max. Prop Diameter	18 inches
Available Gear Ratios	1.69:1, 1.53:1, 1.40:1, 1.30:1
Proshaft Rotation	Left Hand or Right Hand Rotation
Drive Weight (lbs./kg.)	280 / 127

### KEY ATTRIBUTES

#### Winning Combination

✓ Combines best features of the dry-sump **NXT<sup>1</sup>** & **Six** drives. Dry-sumped for maximum power-output. **Delivers 35% more power capacity than the legendary Six drive.**

#### Lower Center of Gravity

✓ Two inches shorter resulting in an overall lower center of gravity for improved handling and overall boat performance. **Superior Maneuverability.**

#### Surface Piercing Gearcase

✓ All-new surface piercing gearcase, packed with heavy-duty components, is designed specifically to handle the 1350's higher torque. **Ultra smooth power.**

#### Pro Finish CNC Propellers

✓ **5 & 6-blade CNC** sterndrive propellers are designed with stamina to allow the engine to endure in both treacherous and ideal offshore conditions. **Performance and Durability.**

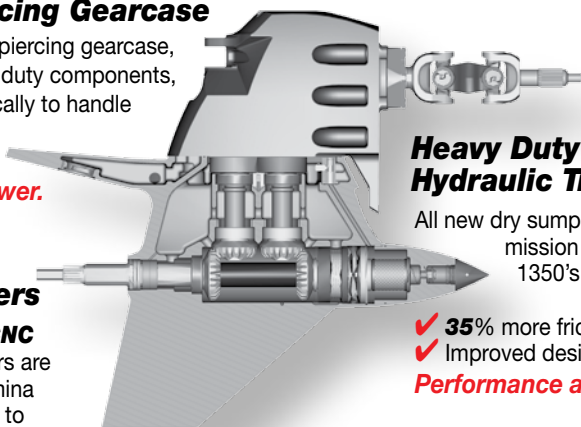

#### Heavy Duty Hydraulic Transmission

All new dry sump hydraulic transmission to handle the 1350's massive torque.

✓ **35% more friction surface.**  
✓ Improved design and materials. **Performance and Durability.**

#### Exclusive Drive Oil Pump

✓ While the lower drive cavity is bathed in oil, a unique propshaft driven oil pump sprays the upper drive gears. This reduces internal friction, increasing performance. **Increased Endurance and Performance.**

## KEY ATTRIBUTES

### ✓ **Twin Pinion Gear Shaft Design**

**A time-proven Mercury Exclusive.** First patented by Mercury for outboard racing back in the **1950s**, this Innovative design splits the torque load for a high power capacity while maintaining a slim gear housing shape for hydrodynamic efficiency.

**Performance with Durability.**

### ✓ **Active Anode**

An active anode enhances corrosion resistance by adjusting its current to the protection need. **More long term protection.**

### ✓ **Product Protection**

**One-year factory warranty and support from world's largest marine service dealer network and Mercury Racing's T.E.A.M. accreditation program provides the best coverage in the industry.**

## **Zero Effort<sup>®</sup> Digital Control**

The newly designed, ergonomic Zero Effort Digital Control delivers precision that makes throttling effortless. Utilizing the Propulsion Control Module (PCM) microprocessor (*the brain behind the engine's brawn*) we achieved a seamless integration for optimal control.



## **Zero Effort<sup>®</sup> Controls**

Zero Effort Controls work with sterndrive, inboard and outboard powered boats. They feature Mercury Racing's pioneering stackable, modular design which enables the controls to be offered in one to six-lever configurations. Throttles and shifters can be grouped separately or combined into a single unit.