

# Section 14 - Miscellaneous Tools Group

This section contains many diverse capability tools. They include generator set applications, temperature measurement, pullers and others for the Miscellaneous Group family. See below for a general description of contents for this grouping of tools.

Tool Description	Page
Engine Fittings .....	14-3
Equipment .....	14-4
Power Generation .....	14-14
Pullers .....	14-17
Temperature Measuring Devices .....	14-18

### Engine Fittings

The following miscellaneous fittings are quick connect fittings used when troubleshooting or diagnosing various pressure drops in an engine.

Ref. No.	Part No.	Description
1	337244	Fittings Kit (contains 7 of PN 337244 & 2 PN 337516)
2	337580	Female Quick Connect 1/2 NPT
3	337544	Female Quick Connect 1/4 NPT
4	337544	Male Quick Connect 1/2 NPT
5	337244	Male Quick Connect 1/4 NPT
6	332300	Male O-ring Seal 2 1/2 UNF
7	337516	Male Quick Connect Elbow 1/2 O-ring Seal
8	337540	Probe Seal Adapter 1/2 NPT
9	362300	Probe Seal Adapter 1/2 UNF O-ring Seal
10	337172	Screw Elbow 1/2 NPT x 1/2 12 SAE Seal 1/2 NPT (approx. 1000 lbs. pressure per sq. in.)
11	332300	Diagnostic Fittings 1/4 NPT ID
12	332302	Flare Reducing Bushing - 1/2 NPT L.D. x 1/4 NPT O.D. to install 337580 Quick Connect fitting
13	337300	Flare Reducing Bushing - 1/2 NPT L.D. x 1/2 NPT O.D. to install 337244 Quick Connect fitting
14	337300	Quick Disconnect Connector - 1/2
15	3324841	Quick Disconnect Connector - 1/12
16	337304	Quick Disconnect Connector - 1/12

## Engine Fittings

3377243

Miscellaneous Engine Fittings

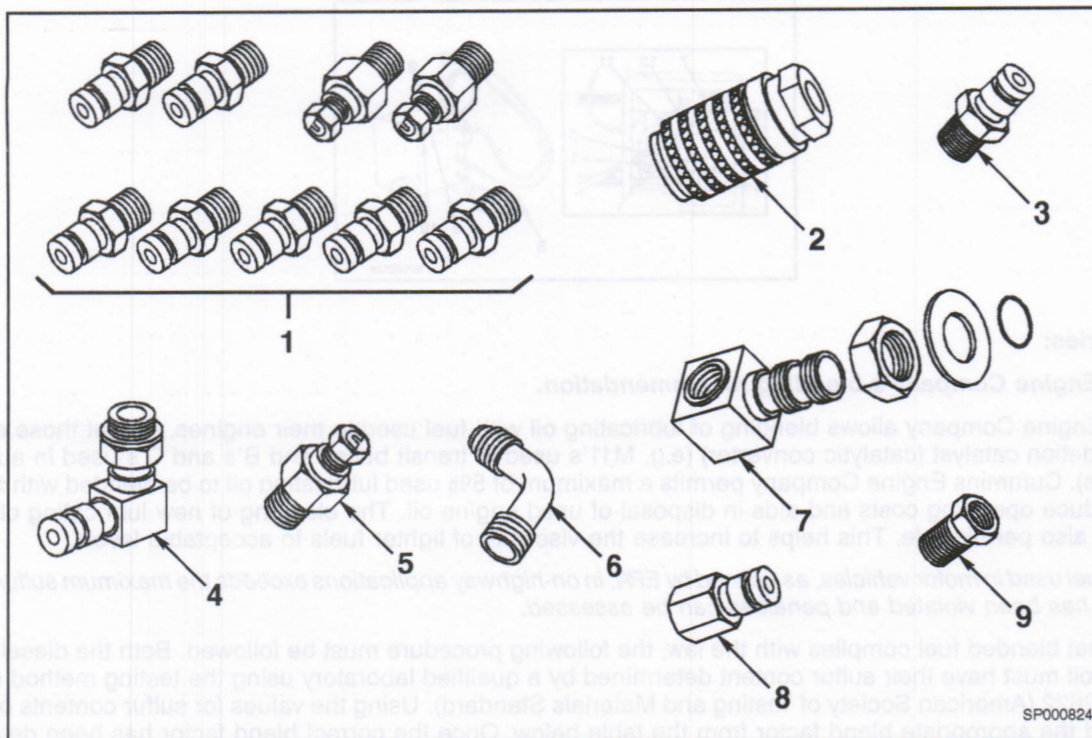

### Engine Series:

The following miscellaneous fittings are quick connect fittings used when troubleshooting or diagnosing various pressure points of an engine.

Ref. No.	Part No.	Description
1	3377243	Fittings kit (contains 7 of PN 3377244 & 2 PN 3376516)
2	3376859	Female Quick Connect 1/8 NPT
2	3376920	Female Quick Connect 1/4 NPT
3	3377244	Male Quick Connect 1/8 NPT
3	3376860	Male Quick Connect 1/4 NPT
3	3377245	Male O'ring Seal 9/16 UNF
4	3823030	Male Quick Connect Elbow 9/16 O'ring Seal
5	3376516	Probe Seal Adapter 1/8 NPT
5	3377246	Probe Seal Adaptor 9/16 UNF O'ring Seal
6	3822303	Street Elbow - 1/2 NPT x No. 12 SAE with 1/8 NPT tapped thread for pressure pick up
7	3377172	Street Elbow 9/16 O'ring Seal, male & female
8	3822998	Diagnostic Fittings 1/4 NPT ID
9	3823202	Pipe reducing Bushing - 1/4 NPT I.D x 3/8 NPT O.D to install 3376860 Quick Connect fitting
9	3823203	Pipe Reducing Bushing - 1/8 NPT I.D. x 3/8 NPT O.D. to install 3377244 Quick Connect fitting
3	3824842	Quick Disconnect Connector - M10
3	3824843	Quick Disconnect Connector - M12
3	3824844	Quick Disconnect Connector - M14

## Equipment

3376317

Fuel/Lube Oil Blenders

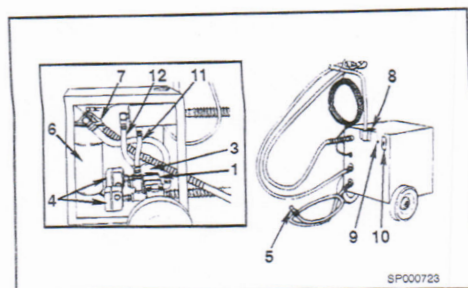

### Engine Series:

#### Cummins Engine Company's blending recommendation.

Cummins Engine Company allows blending of lubricating oil with fuel used in their engines, except those equipped with an oxidation catalyst (catalytic converter) (e.g. M11's used in transit buses and B's and C's used in automotive applications). Cummins Engine Company permits a maximum of 5% used lubricating oil to be blended with fuel. This helps to reduce operating costs and aids in disposal of used engine oil. The blending of new lubricating oil to raise viscosity is also permissible. This helps to increase the viscosity of lighter fuels to acceptable levels.

*If blended fuel used in motor vehicles, as defined by EPA, in on-highway applications exceeds the maximum sulfur content, federal law has been violated and penalties can be assessed.*

To insure that blended fuel complies with the law, the following procedure must be followed. Both the diesel fuel and lubricating oil must have their sulfur content determined by a qualified laboratory using the testing method specified in ASTM D2622 (American Society of Testing and Materials Standard). Using the values for sulfur contents of the fuel and oil, find the appropriate blend factor from the table below. Once the correct blend factor has been determined, multiply this by the volume for fuel to be blended, the result is the amount of this oil that can be blended with this fuel and remain within legal limits. *Note: State or local regulations may prohibit the blending of lubricating oil with fuel. Check state and local regulations. See example below for proper mixture.*

#### Blend Factor Table

To determine the blend factor, locate the column in the table that corresponds to the sulfur content of the fuel, then find the row that corresponds to the sulfur content of the oil. The correct factor will be the value at the intersection for the row and column.

As an example, consider 50,000 gallons of fuel with a sulfur content of 0.04% by weight and lubricating oil with a sulfur content of 0.5 by weight. Using the below table shows a blend factor of 0.009. Multiply this by the amount of fuel to be blended:

Gallons of oil that can be blended = 50,000 (gallons fuel) X 0.009 (factor from table) = 450 (gallons of oil). [50,000 X 0.009 = 450] Therefore, 450 gallons of this oil can be blended with 50,000 gallons of this fuel and remain within legal limits for sulfur content.

The values in the blend factor table have been calculated to account for differences in fuel and lubricating oil density and measurement error. Due to the accuracy of the test for sulfur content, it is not safe to blend lubricating oil with fuel that has a sulfur content above 0.045% by weight.

Lube Oil % Sulfur by Wgt.	Fuel % Sulfur by Weight								
	0.005	0.010	0.015	0.020	0.025	0.030	0.035	0.040	0.044
0.10	0.612	0.536	0.459	0.383	0.306	0.230	0.153	0.077	0.015
0.15	0.321	0.281	0.241	0.201	0.160	0.120	0.080	0.040	0.008
0.20	0.217	0.190	0.163	0.136	0.109	0.081	0.054	0.027	0.005
0.25	0.164	0.144	0.123	0.103	0.082	0.062	0.041	0.021	0.004
0.30	0.132	0.116	0.099	0.083	0.066	0.050	0.033	0.017	0.003
0.35	0.110	0.097	0.083	0.069	0.055	0.041	0.028	0.014	0.003
0.40	0.095	0.083	0.071	0.059	0.047	0.036	0.024	0.012	0.002
0.45	0.083	0.073	0.062	0.052	0.042	0.031	0.021	0.010	0.002

Lube Oil % Sulfur by Wgt.	Fuel % Sulfur by Weight								
	0.005	0.010	0.015	0.020	0.025	0.030	0.035	0.040	0.044
0.50	0.074	0.065	0.056	0.046	0.037	0.028	0.019	0.009	0.002
0.55	0.067	0.058	0.050	0.042	0.033	0.025	0.017	0.008	0.002
0.60	0.061	0.053	0.046	0.038	0.030	0.023	0.015	0.008	0.002
0.65	0.056	0.049	0.042	0.035	0.028	0.021	0.014	0.007	0.001
0.70	0.051	0.045	0.039	0.032	0.026	0.019	0.013	0.006	0.001
0.75	0.048	0.042	0.036	0.030	0.024	0.018	0.012	0.006	0.001
0.80	0.045	0.039	0.033	0.028	0.022	0.017	0.011	0.006	0.001
0.85	0.042	0.037	0.031	0.026	0.021	0.016	0.010	0.005	0.001
0.90	0.039	0.034	0.030	0.025	0.020	0.015	0.010	0.005	0.001
0.95	0.037	0.033	0.028	0.023	0.019	0.014	0.009	0.005	0.001
1.00	0.035	0.031	0.026	0.022	0.018	0.013	0.009	0.004	0.001

The Cummins Service Products Company Fuel/Lube Oil Blender is a remarkable device that quickly, safely, economically and conveniently blends used lubricating oil with diesel fuel for use in the engine without affecting the engine's performance and fuel economy.

The Blender can be used in a wide variety of diesel engine applications, including on-highway, construction, agriculture, marine and stationary power units. The Blender can be a valuable asset to cost savings in a number of ways. It provides a method of disposing of used lube oil that is within regulations while offsetting high fuel costs by utilizing the used oil as a fuel supplement.

The Blender is both quick and simple to use and is compatible with a majority of makes and models of diesel engines. Equipping of the engine with a quick disconnect hose assembly, which replaces the oil pan plug, will streamline the operation. The quick disconnect access end can then be mounted in a convenient location using a special mounting bracket.

To blend the engine's used lubricating oil for utilization as a fuel supplement, the Blender's suction hose is attached to the quick disconnect fitting. Then the fuel suction hose and the blended fuel return hose are inserted into the unit's fuel tank.

Once the hoses are in place, the Blender performs its operation automatically with the push of a button. It shuts itself off when all of the lube oil in the crankcase has been filtered and blended with fuel oil then pumped into the fuel tanks. Operation is simplified further by a light which indicates that the Blender's power system is running.

*The quick disconnect hose and fittings replace the oil pan plug to streamline and speed operation. Once the fuel suction and blended fuel return hoses are placed in the fuel tanks, the pump operates without supervision.*

*A handy running light indicates the Blender's power system is functioning properly.*

Safety is also an important feature of the Blender. Since manual removal of the oil pan plug is eliminated through the use of the quick disconnect hose assembly, the danger of a person being burned by hot lube oil during the process is also eliminated.

The lube oil is thoroughly filtered by the Blender prior to being blended with fuel oil to remove any impurities. The safety shutdown switch will turn the unit off if pressure is lost. This assures that blending occurs in the prescribed ratio determined by fuel systems experts to be necessary to insure a homogenous fuel mixture. Topping off fuel tanks after blending will insure that the maximum recommended concentration of 5

used lube oil will not be exceeded.

The Blender provides a solution to help fuel costs and drain oil disposal problems in one simple unit. Now a wide range of diesel engine applications can benefit from the Blender. Why not take advantage of fuel/lube oil blending and start increasing your profits now?

Part No.	Description
3376317	Lube Oil Blender 115V/60 Hz. Blender
3376362	Lube Oil Blender 230V/50 Hz. Blender
3822387	Lube Oil Blender 115V/60 Hz. Blender

**NOTE:** 3822387 Blender is less wheels and handle for stationary applications such as marine and certain industrial applications.

Ref. No.	Detail No.	Description
		Replacement parts for 3376317 and 3822387 Blender

Ref. No.	Detail No.	Description
1	3376759	Gear Pump (Lube Oil & Fuel Oil)
2	3823454	Gear Pump Rebuild Kit
3	3375813	Flange Mount Motor (115 V/60 Hz.)
4	3375817	Pressure Switch
5	3375600	Suction Screen
6	3375404	Fuel Filter
7	3375453	Fuel Filter Head
8	3376300	Vacuum Gauge
9	3376328	Push Start Switch
10	3376778	On-Off Switch w/overload
	3376329	Overload
11	3823452	Fuel Mixing Tube
12	3823453	Oil Mixing Tube

Replacement parts for 3376362 Blender are the same as above except the motor  
3376379 Flange Mount Motor (230V/50 Hz.)

Several oil pan adapter kits and quick connect fittings are available to make it cleaner and more productive when connecting the blender to the oil pan. These must all be ordered separately as desired.

**Part No. 3375405 Female Quick Disconnect. This is attached to the Blender hoses and becomes a permanent part of the Blender.**

Order Flow Adapter Kits or hoses so that the male quick disconnect can be located conveniently along a frame rail or attached to the side of the engine.

**3824717 Oil Pan Adapter Kit**

This is for use on L10M411 engines with stamped steel oil pans. This is the only kit recommended when using a stamped steel oil pan. Cast aluminum oil pans may use any of the below listed adapter kits. (Includes Ref. No. 1, 2, 4, 7)

**3822905 Flow Adapter/Hose Kit**

3822906 Flexible Hose No. 8 x 20 in. long  
3822904 Oil Pan Adapter Kit

**3822906 Flow Adapter/Hose Kit**

3822907 Flexible Hose No. 8 x 24 in. long  
3822904 Oil Pan Adapter Kit

**3822907 Flow Adapter/Hose Kit**

3822908 Flexible Hose No. 8 x 30 in. long  
3822904 Oil Pan Adapter Kit

**3822908 Flow Adapter/Hose Kit**

3822909 Flexible Hose No. 8 x 42 in. long  
3822904 Oil Pan Adapter Kit

NOTE: To pull oil from a container when 3822905 Female Quick Connect is connected to the Blender suction hose, insert 3822906 Male Quick Disconnect fitting to open the female quick connect so that flow can be produced.

NOTE: To change from No. 8 Hose to No. 12 Hose the following items should be used: 3822903 - No. 8 Female Connector, 1/2" Pipe Nipple, 3/4"-1/2" Reducer, 3375405 - No. 12 Male (attach + connector bundle)

**3822904  
Oil Pan Adapter Kit**

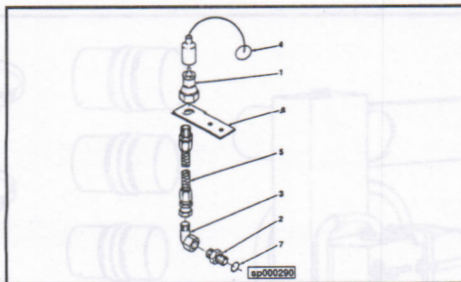

**Engine Series:**

**3822904 Oil Pan Adapter Kit**

Ref. No.	Detail No.	Description
1	3822895	Male Disconnect - 1/2 NPT Female
2	3376293	Oil Pan Drain Adapter 1-18 Male x 1/2 NPT Male
3	3822897	Female Elbow Adapter # 8 SAE Male x 1/2 NPT Female
4	3822896	Dust Cap
5	Flexible Hose	(See Kit P/N)
6	3822894	Flow Mounting Plate
7	3823455	Oil Pan Adapter Gasket

**3824717 Oil Pan Adapter Kit**

This is for use on L10/M11 engines with stamped steel oil pans. This is the only kit recommended when using a stamped steel oil pan. Cast aluminum oil pans may use any of the below listed adapter kits. (Includes Ref. No. 1, 2, 4, 7)

**3822905 Flo Adapter/Hose Kit**

- 3822899 Flexible Hose No. 8 x 20 in. long
- 3822904 Oil Pan Adapter Kit

**3822906 Flo Adapter/Hose Kit**

- 3822900 Flexible Hose No. 8 x 24 in. long
- 3822904 Oil Pan Adapter Kit

**3822907 Flo Adapter/Hose Kit**

- 3822901 Flexible Hose No. 8 x 36 in. long
- 3822904 Oil Pan Adapter Kit

**3822908 Flo Adapter/Hose Kit**

- 3822902 Flexible Hose No. 8 x 42 in. long
- 3822904 Oil Pan Adapter Kit

**NOTE:** To pull oil from a container when 3822903 Female Quick Connect is connected to the Blender suction hose, insert 3822895 Male Quick Disconnect fitting to open the female quick connect so that flow can be produced.

**NOTE:** To change from No. 8 Hose to No. 12 Hose the following items should be used: 3822903 - No. 8 Female Connector, 1/2" Pipe Nipple, 3/4"-1/2" Reducer, 3375406 - No. 12 Male (attach + connector blender)

Dynamometer Room Charge Air Cooler

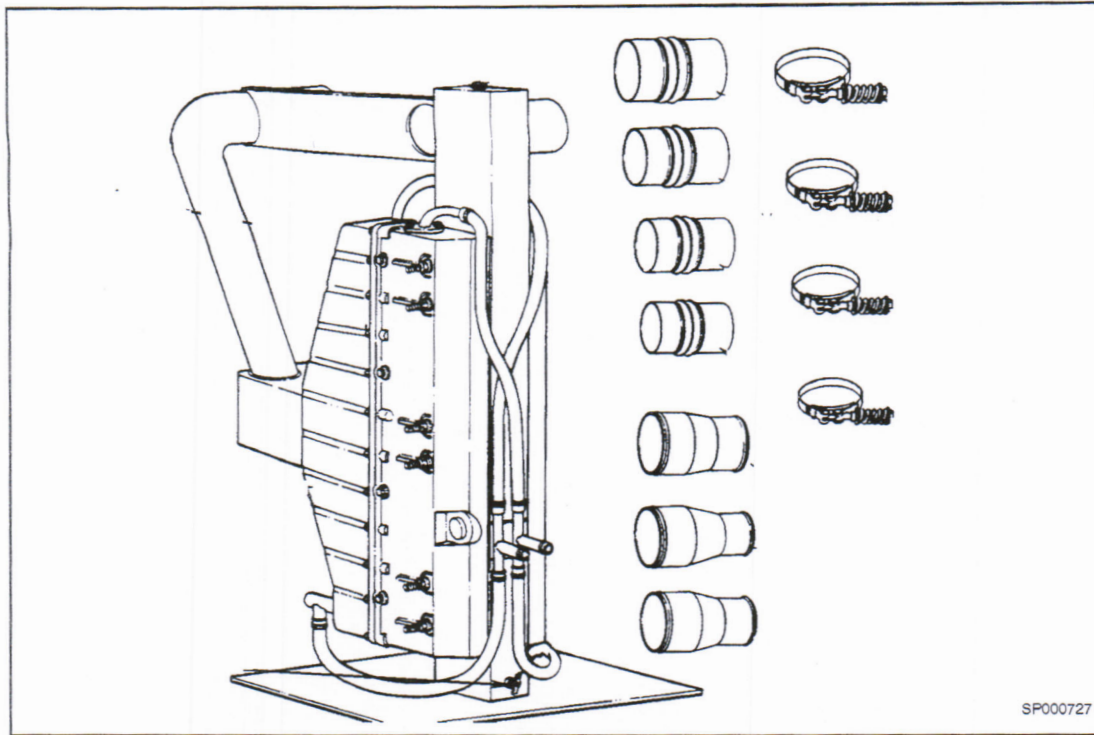

**Engine Series:**

When testing a Cummins engine in a dynamometer room, out of frame, a Dynamometer Room Charge Air Cooler (CAC) must be used if the engine is from an application that is equipped with a charge air cooler. Many of today's applications, from the Cummins B Series engine through and including the N14 Plus engine are equipped with charge air cooling.

The CAC Kit includes an aftercooler/intake manifold assembly and miscellaneous hoses and hose clamps to connect to the engine intake manifold. The aftercooler is water cooled from a local water supply.

**3824319**  
**Coolant Dam/Pressure Tester**

**Engine Series:**

*Patent Pending*

**Don't Drain the Block**

Using your shop air supply the "Coolant Dam™ Pressure Tester" creates a vacuum, holding coolant in with little or no coolant loss. For many minor repairs, there is no need to spend valuable shop time draining and refilling the system. Unit fits standard radiator necks and installs as quickly as a radiator cap. Adapters are available to fit special applications.

As a pressure tester, this unit quickly checks your repair with positive pressure from shop air without tedious hand pumping. A radiator cap installs on tester to provide pressure relief. An inlet ball valve adjusts the pressure applied to the system up to the maximum limit of the relief valve (radiator pressure cap).

**Uses Shop Air Supply**

Ingenious and simple, this new timesaving tool holds the engine coolant in, even when pipe plugs, sensors, valves etc. are removed for replacement or repair.

Simple, effective and a tremendous time saver. Pays for itself after just a few uses. High quality metal body is chrome plated for durability. Includes storage case.

In the vacuum mode, shop air passes through the unit and holds coolant in the system. Simply adjust the inlet valve to the required vacuum reading on the gauge.

As a tester the tool utilizes shop air supply to safely pressurize systems.

Easy to read gauge shows pressure on coolant. Maximum pressure exerted on the cooling system is controlled by a standard automotive radiator cap.

Air Requirement for continuous use: Approximately 30 CFM @ 120-150 PSI.

Considering an average drain and refill requires 12-15 minutes, you can compute your savings using your current shop rates.

**Helps reduce man hours on many of the following:**

- Changing heater hoses
- Changing automatic fan sensors
- Changing coolant temperature sensors
- Installing coolant shut off valves for fuel warmers and separators
- Replacing cab heater cores
- Replacing heater control valves
- Eliminating tedious hand pumping
- Provides continuous pressure to diagnose hard to find coolant leaks
- Changing air compressor or air compressor head
- Helps do away with coolant spills
- Your shop may find many other uses

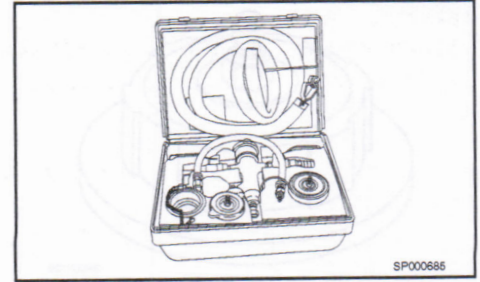

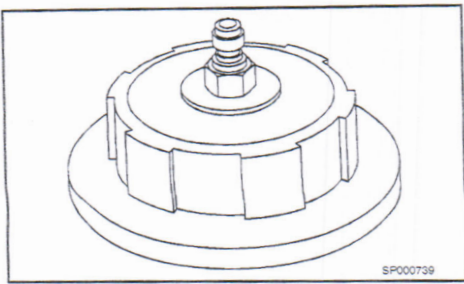

**3164211  
Adapter**

**Engine Series:**  
Navistar 1996 or newer (fits on radiators using Navistar part # 2039390C1).

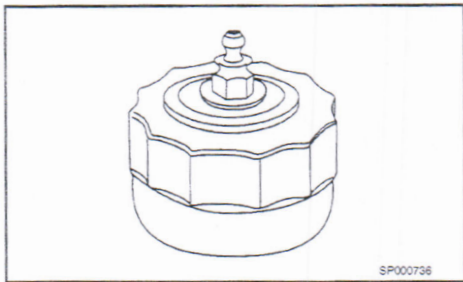

**3824311  
Adapter**

**Engine Series:**  
Mack Midliner to quick coupler. (Fits on radiators using Mack part #5516031410 radiator cap)

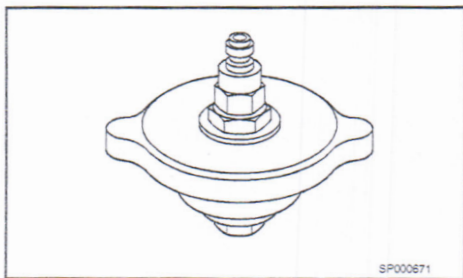

**3824312  
Adapter**

**Engine Series:**  
Mercedes truck to quick coupler. (Fits on radiators using Mercedes Part No. 3445010315 radiator cap)



**3824294  
Rubber Expansion Plugs**

**Engine Series:**

Part No.	Description
3824294	Rubber Expansion Plug $\frac{3}{8}$ "
3824295	Rubber Expansion Plug $\frac{7}{16}$ "
3824296	Rubber Expansion Plug $\frac{1}{2}$ "
3824297	Rubber Expansion Plug $\frac{9}{16}$ "
3824298	Rubber Expansion Plug $\frac{5}{8}$ "
3824299	Rubber Expansion Plug $\frac{11}{16}$ "
3824300	Rubber Expansion Plug $\frac{3}{4}$ "
3824301	Rubber Expansion Plug $\frac{13}{16}$ "
3824302	Rubber Expansion Plug $\frac{7}{8}$ "

Note: (2) 3824294 Plugs are included in 3824319 Kit

**3824313  
Adapter**

**Engine Series:**

Volvo (threaded 46 x 3 mm) to quick coupler. (Fits on radiators using Volvo part #1542591 radiator cap)

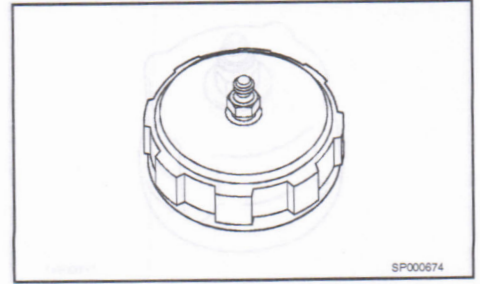

**3824314  
Adapter**

**Engine Series:**

Truck (B) size to quick coupler

**NOTE:** Included in 3824319 Kit

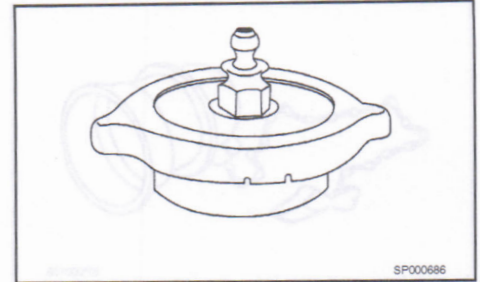

**3824315  
Adapter**

**Engine Series:**

High flow standard automotive size Cam lock adapter (For improved vacuum holding ability)

**NOTE:** Included in 3824319 Kit

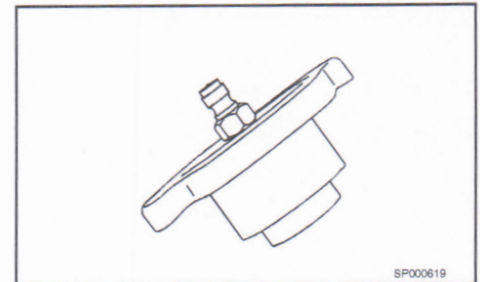

**3824316  
Adapter**

**Engine Series:**

Threaded non-vented cap for some late model Western Star and also older GMC and Freightliner.

(Fits on radiators using Western Star part #20009-0002 radiator cap)

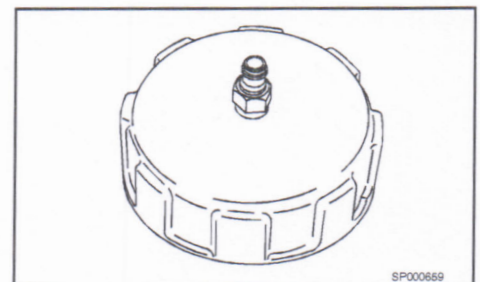

**3824317  
Adapter**

**Engine Series:**

Transit Bus Adapter.



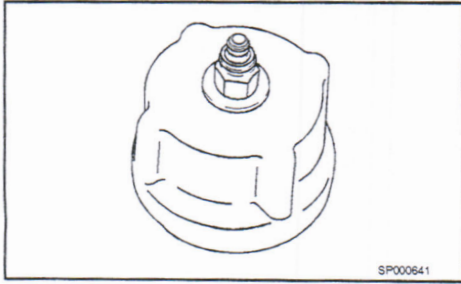

**3824318  
Adapter**

**Engine Series:**

Volvo (threaded 63 x 3 mm) to quick coupler adapter.  
(Fits on radiators using Volvo part #6794968 radiator cap)

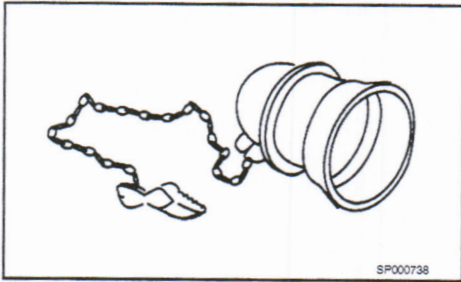

**3824430  
Adapter**

**Engine Series:**

Mount on top of Coolant Dam to test pop-off pressure of Truck B size cap.

**NOTE:** Included in 3824319 Kit

**3824340**  
**Clutch Caddy**

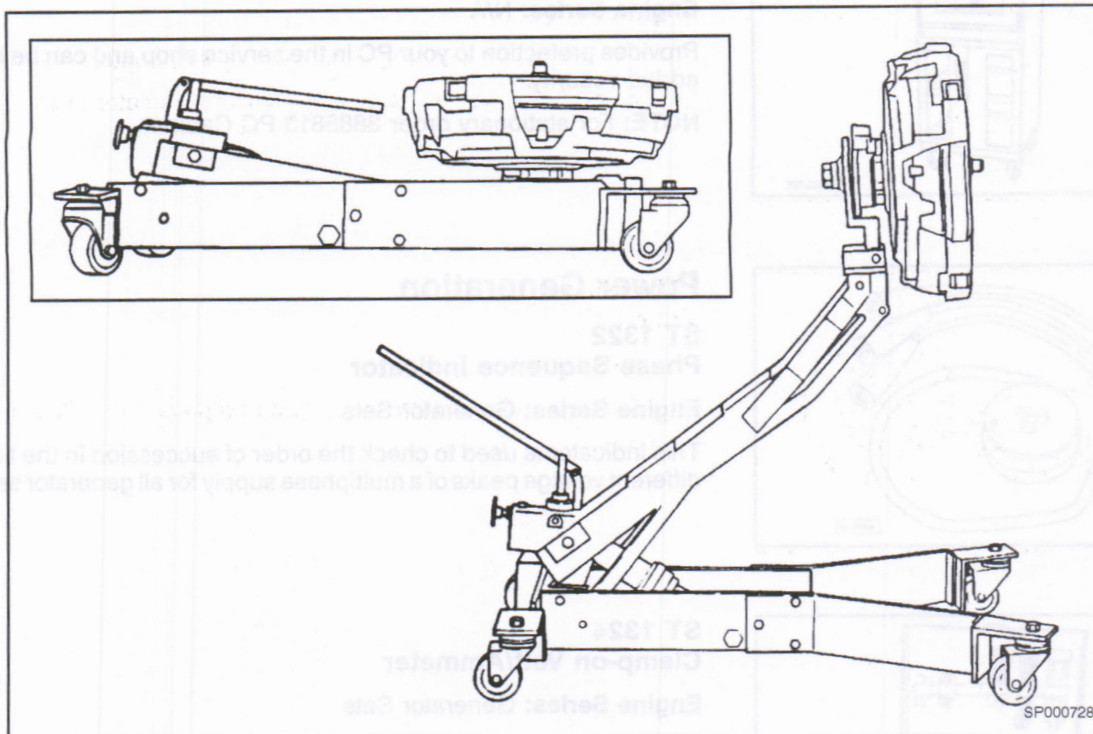

**Engine Series:**

The Clutch Caddy has a height of 13" in the lowered position with a clutch in place. It has a maximum height of 39".

The Clutch Caddy is designed to help a mechanic install and remove heavy 14" and 15 1/2" truck clutches and flywheels in the close-quarter environment under a truck.

The Clutch Caddy includes adapters for 14" and 15 1/2" clutches with 2" shaft.

The Clutch Caddy is a unique and patented tool that minimizes the danger of back injuries, hernias, crushed fingers, fractured feet and toes by taking the heavy lifting out of the mechanics hands. It enables one mechanic to raise, position, and install a heavy clutch under a truck.

The Clutch Caddy consist of a rugged steel base, hydraulic lifting arm, and industrial type casters.

The Clutch Caddy is easy to use. The clutch is loaded in a flat position on the splined shaft, then raised and pivoted to an upright position under the truck. It has a height of only 13" in the lowered position with a clutch in place. It has a maximum height of 39".

There are several attachments for the Clutch Caddy that aide in additional component removal and installation. There are adapters for flywheels, differentials, drive shafts, starter motors, and auxiliary cases. There are three additional splined shafts for different sized clutch applicaitons. The attachments mount on a rotating base that has an adjusting screw to assist in aligning components.

**Clutch Caddy Optional Part Numbers**

Part No.	Description
3824342	Flywheel Adapter handles flywheels for 14" and 15 1/2" clutches
3824341	Splined Shaft for 14" and 15 1/2" clutches with 1 3/4" shaft x 1" pilot
3824948	Splined Shaft 1 3/4" Dia. x .983" pilot
3824949	Splined Shaft 1 1/2" Dia. x .981" pilot
3824950	Drive Shaft Adapter
3824951	Starter Motor Adpater
3824952	Auxilliary Case Adpater
3824953	Differential Adapter



**3885812**  
**PC Shop Cabinet - Mobile**

**Engine Series:** N/A

Provides protection to your PC in the service shop and can be locked for added security.

**NOTE:** For stationary order 3885813 PC Cabinet.

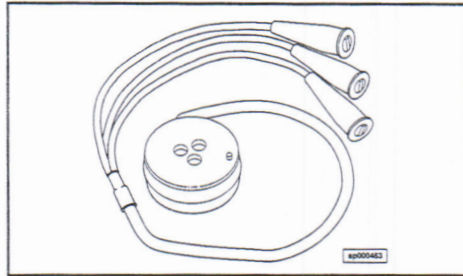

**Power Generation**

**ST 1322**  
**Phase Sequence Indicator**

**Engine Series:** Generator Sets

This indicator is used to check the order of succession in the time of the different voltage peaks of a multiphase supply for all generator set service.

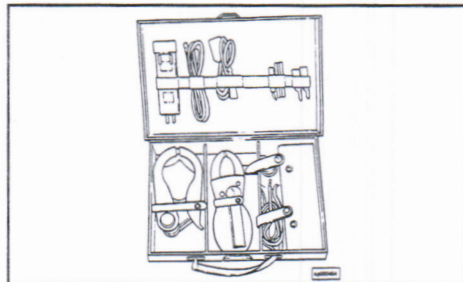

**ST 1324**  
**Clamp-on Volt/Ammeter**

**Engine Series:** Generator Sets

This tester is used to measure Amps, Volts (AC) and Ohms on generator sets without interrupting operation of the unit.

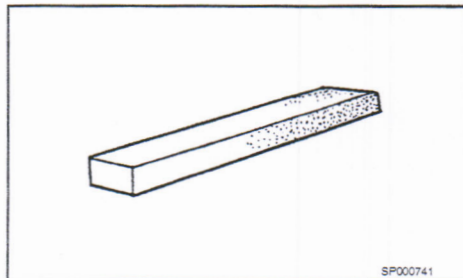

**3162370**  
**Brush Seating Stone**

**Engine Series:** Onan

This stone is a special compound for rapid seating of new brushes on commutators and slip rings.

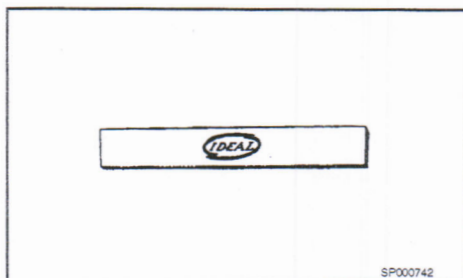

**3162371**  
**Commutator Stone**

**Engine Series:** Onan

Used for smoothing rough commutators or slip rings. It quickly removes carbon glaze.

**3162376**  
**Red Lead Assembly**

**Engine Series:** Onan

6 foot long heavy duty cable with lug to connect to panel and battery clip to connect to generator.

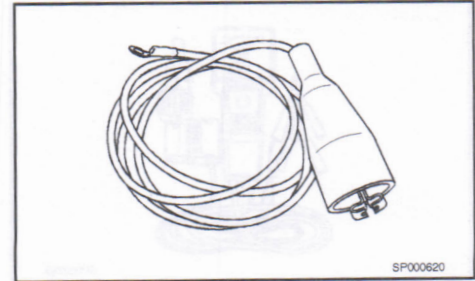

**3162377**  
**Black Lead Assembly**

**Engine Series:** Onan

6 foot long heavy duty cable with lug to connect to panel and battery clip to connect to generator.

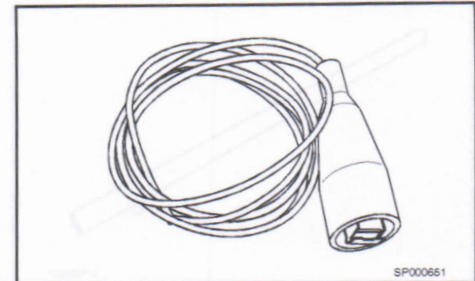

**3162388**  
**AC Volt Tester**

**Engine Series:** Onan

Test AC line voltage from 0-150 volts.



**3162415**  
**Headless Bolt**

**Engine Series:** Onan

Use with  $\frac{9}{16}$ -12 x 1  $\frac{3}{4}$  inch bolt to remove the rotor on Emerald Generators. Also included in 3162417.

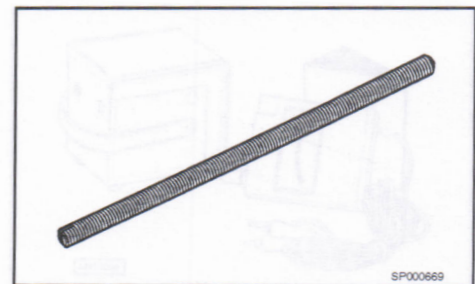

**3162418**  
**Microlite Flywheel Puller**

**Engine Series:** Microlite Gen Set

This special tool is designed for holding the fan hub on the Microlite GenSet so as not to damage the cooling fins and also doubles as a puller to remove the fan hub from the rotor shaft.

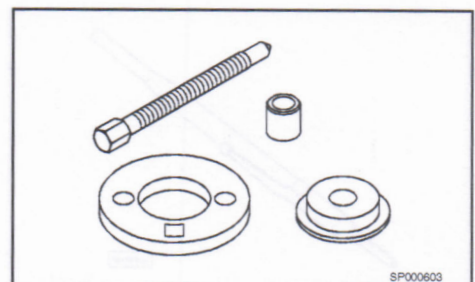

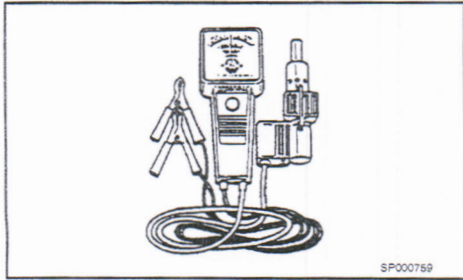

**3162419**  
**Portable Exhaust Analyzer**

**Engine Series:** Onan

Provides pinpoint test accuracy that a serious mechanic demands. Check carburetor condition and air/fuel ratio on most engines simply and accurately.

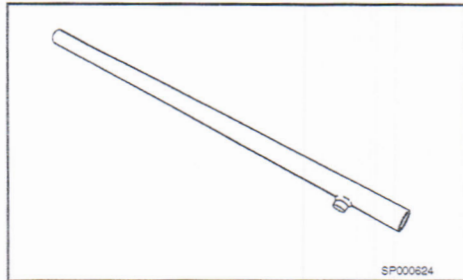

**3163154**  
**Exhaust Probe**

**Engine Series:** Onan

For use in sampling CO levels on Onan P248V Floor Care engines.

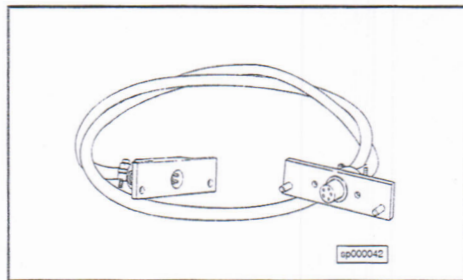

**3375363**  
**Adapter Cable Extension**

**Engine Series:** Generator Sets

This special cable is used on Barber Colman governors and allows for the control box to be removed from the assembly and the needed adjustments made. This applies to Gen Set engines only.

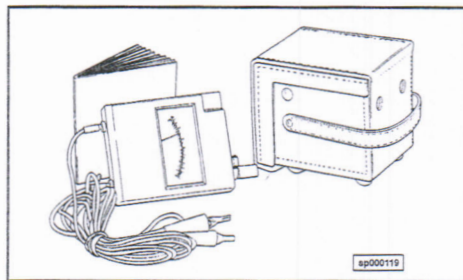

**3376304**  
**Megger Meter**

**Engine Series:** All Generator Sets

This special meter is used for testing performance by generator set service and application personnel. This unit is used to measure insulation resistance values and other high resistance tests. It is also used for continuity ground and short circuit testing. Specifications are: Range: 0-100 Mega ohms, 0-500 ohms, Voltage Range DC: 500 Volts Accuracy: Plus or minus 0.9 mm (.035 in.) from any marked position on the scale. The kit includes a case, 6 ft. leads and instructions.

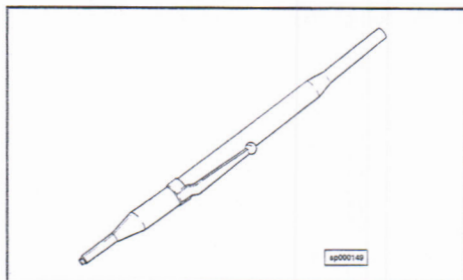

**3376613**  
**Trim Pot Screwdriver**

**Engine Series:** Generator Sets

This small screwdriver is especially made to adjust electronics trim pots on electronic governors or other units found on generator sets or other electronic products that can be adjusted.

**3822206**  
**Pin/Socket Extraction Tool**

**Engine Series:** All

This tool is used to remove the pin and socket contacts from various connectors on the Cummins generator sets.

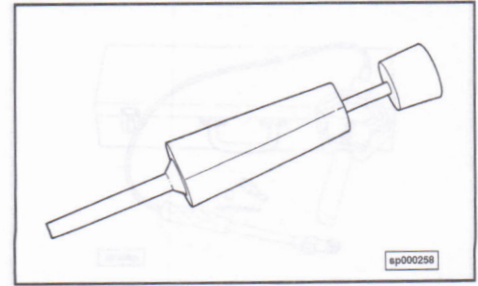

**Pullers**

**3375779**  
**Puller Kits, Medium Duty**

**Engine Series:** All

These kits provide medium range pullers for general purpose use. The kit assembles up to four pullers at the same time covering a range of 3/4 in. spread, on inside pulls, to 10 inch spread on outside pulls. Jaws are spring loaded, reversible and feature positive grip for safety and convenience. The kit allows for either slide hammer or pressure screw power.

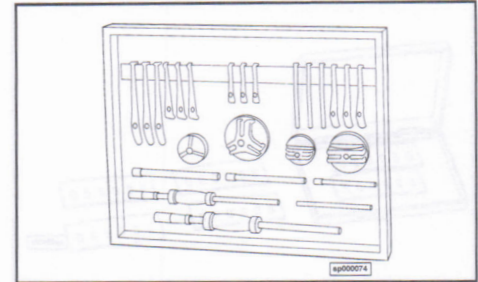

Part No.	Description
3375779	Puller Kit
3375780	Puller Kit in Metal Box (3375779 Kit in Metal Box)

**3375783**  
**10 Ton Hydraulic Puller**

**Engine Series:** All

This heavy duty puller has many uses around the shop for general purpose use. The ram is 4 3/4 inch long, 2 5/8 diameter, with a 15 inch long pressure screw. 6 feet of hydraulic hose with quick coupler to the cylinder is also provided.

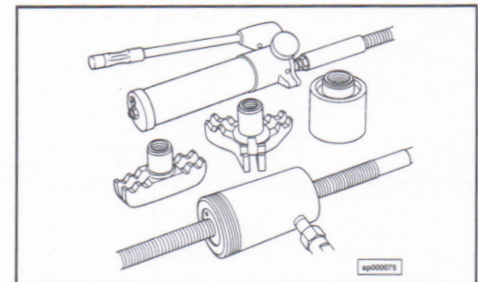

**3375784**  
**Puller Set, Light Duty**

**Engine Series:** All

This small, light duty puller set has many uses such as remove small seals, sleeves, bearings, grease retainers, bronze or oil-lite bushings, bearing races and bushings as small as 3/4 inch inside diameter. The two sets of smaller jaws range from 25/64 to 1 1/4 in. inside diameter. The larger jaws have a maximum of 3 inch spread for outside holds and 2 1/2 inch jaw reach. The set offers the advantage of 2 jaw or 3 jaw puller.

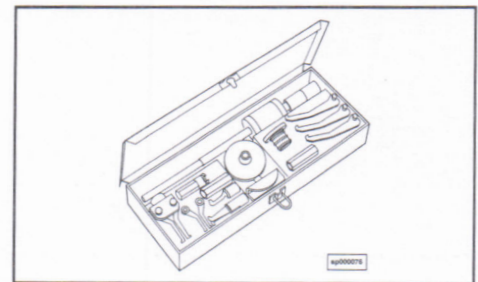

## Temperature Measuring Devices

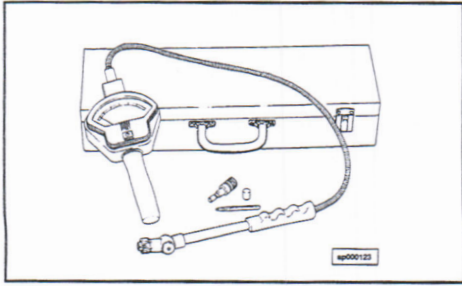

### 3376336 Contact Surface Pyrometer

**Engine Series:** All

This kit is used to check exhaust manifold temperatures and other related high temperatures. The pyrometer has a temperature range of 0-1200 degrees F with a 42 inch flexible extension arm and thermocouple for any stationary surface. A carrying case is also included.

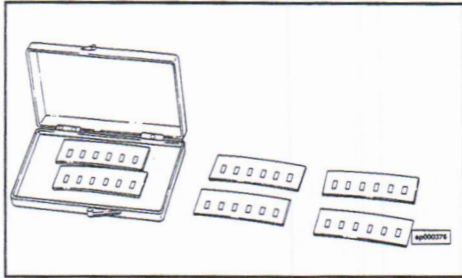

### 3164078 Temperature Monitor Label Kit

**Engine Series:** All

These stick on labels monitor temperatures. Each label contains 6 windows that turn black as the temperature reaches a predetermined temperature rating of the label. Each label window is designed for a 10 degree temperature increase. These labels are very useful where electrical recording devices are not practical.

Part No.	Description
3164078	Temperature Monitor Labels 130 deg. min./180 deg. max. (contains 10 each of 3824073)
3164079	Temperature Monitor Labels 190 deg. min./240 deg. max. (contains 10 each of 3824074)
3164080	Temperature Monitor Labels 250 deg. min./300 deg. max. (contains 10 each of 3824075)